

# **The Perception of Temporal Order: Fundamental Issues and a General Model**

**Saul Sternberg and Ronald L. Knoll**  
**Bell Laboratories, Murray Hill, New Jersey**

*Dedicated to the Memory of Robert R. Bush*

629	<b>Abstract</b>
630	<b>1 Introduction</b>
	1A Experimental paradigm
	1B Evidence for a central timing mechanism
635	<b>2 Independent-Channels Model</b>
	2A The general model
	2B Additive representation of the psychometric function for the deterministic decision rule
	2C Six models of the decision mechanism
	2D Additive representation of the psychometric function for the general model
643	<b>3 Comparison of Order Judgments and Reaction Time to Test the Independent-Channels Model</b>
	3A Comparison of $D(x,y)$ and $T_x - T_y$
	3B Comparison of changes in $D(x,y)$ and $T_x$ : Equality of factor effects
648	<b>4 The Concept of Perceptual Latency</b>
650	<b>5 Additive-Factor Tests of the Independent-Channels Model</b>
	5A Selective influence of factors on channels: Additivity of factor effects
	5B Tests of factor additivity in three visual experiments
	5C Additive-factor test of an independent-channels model of binaural lateralization
	5D Use of the time-intensity trading relation to trace information flow
	5E Channels, stages, and additive factors
659	<b>6 Prior Entry: Effect of Attentional Bias on Temporal-Order Perception</b>
662	<b>7 Potential Effects of Interchannel Interactions</b>
663	<b>8 Transitivity of Subjective Simultaneity and the Existence of a Common Simultaneity Center</b>
	8A Transitivity of arrival latencies and decision functions
	8B Further implications of a common decision center
	8C Tests of transitivity in three experiments
	8D Pathway differences and the variation of intransitivity with stimulus intensity
672	<b>9 Order Judgments of Multiple Stimuli</b>
	9A Relation to theoretical issues
	9B Characteristics of existing studies using multiple stimuli
674	<b>10 Comments on Experimental Method</b>
	10A Multiple-observation methods
	10B Biasing effects of stimulus range
	10C Purity of stimulus information
	10D Control of attentional bias
	10E Dangers of averaging
	10F Estimation of cumulants of the psychometric function
678	<b>11 Real-Time Processing without Memory</b>
680	Glossary
680	Acknowledgments
681	References

In S. Kornblum (Ed.),  
*Attention and performance IV.*  
New York: Academic Press, 1973. Pp. 629-685.

## **The Perception of Temporal Order: Fundamental Issues and a General Model<sup>1</sup>**

*Saul Sternberg    Ronald L. Knoll*

*Bell Laboratories  
Murray Hill, New Jersey*

*Dedicated to  
the Memory of  
Robert R. Bush*

### *ABSTRACT*

How do people judge the order of two nearly simultaneous stimuli, such as a light and a tone? We consider this question in the context of a general independent-channels model that incorporates most existing models of order perception as special cases, and which has been implicitly assumed when temporal-order judgments are used to study perceptual latency. In the model, a "decision function" converts a difference in central "arrival times" of two sensory signals into an order judgment. The psychometric function for order is regarded as a distribution function, and can be represented additively in terms of the central arrival latencies and the decision function. Various distinct decision functions correspond to various previously proposed mechanisms involving a "perceptual moment," attention switching, a threshold for arrival-time differences, and so forth (Section II).

One test of the model is to compare reaction-time measurements with order judgments (Section III). Discrepancies can be understood by an analysis of the concept of perceptual latency that recognizes the internal response to a pulse as being spread out in time (Section IV).

---

<sup>1</sup>A glossary of symbols and abbreviations may be found at the end of the text.

An alternative test is to determine whether experimental factors that influence two signal channels selectively have additive effects on the mean, variance, and higher cumulants of the psychometric function for order, as the general model implies. Some data confirm the model when examined in this way, but others do not. We consider extensions of the model from order judgments to other perceptual domains in which the relative arrival time of a pair of signals is thought to determine the percept. An additivity test applied to binaural lateralization favors extending the model to that phenomenon, and suggests a new method for tracing information flow in sensory channels by analyzing time-intensity trading relations at different "levels." Such an analysis reveals different effects of stimulus intensity on latency for different visual tasks, and leads to speculations about the locus of stereoscopic depth perception in relation to other processes (Section V).

The influence of attentional bias on the point of subjective simultaneity makes tests of the model difficult. However, the model suggests how to study this "prior-entry" phenomenon and determine whether attention influences the sensory channels or the decision mechanism (Section VI).

Implications of transitivity of perceived order are examined, particularly in relation to the idea of a single multisensory "simultaneity center" in the brain; some experimental tests of transitivity are reviewed (Section VIII).

The problem of perceived order of three or more stimuli bears on several important questions, including transitivity. But existing experiments with multiple stimuli shed little light on these issues (Section IX).

Several aspects of experimental method are considered (Section X).

## I. Introduction

That the perceived temporal order of a pair of stimuli might not correspond to their actual order had already been recognized when experimental psychology began, and the source of errors in judgments of order and simultaneity is one of the oldest of our unsolved problems. Since the work of Bessel and other 19th century scientists, it has been known that observers differ systematically, that objectively simultaneous stimuli may consistently fail to be subjectively simultaneous, and that there are variations from one judgment to the next of the same pair of stimuli (Sanford, 1888; Dunlap, 1910).

Although the mechanisms responsible for these effects are not yet well understood, experiments involving judgments of temporal order or simultaneity have nonetheless been used to attack problems in fields that range from sensory mechanisms to psycholinguistics, including, for example, the dependence of sensory latency on stimulus intensity (Roufs, 1963), identification of speech sounds (Liberman, Harris, Kinney, & Lane, 1961), lateralization of function in the cerebral hemispheres (Kappauf & Yeatman, 1970), duration of visual images (Sperling, 1967), selective attention (Stone, 1926), comprehension of sentences (Reber & Anderson, 1970), perception

of melodic lines (Bregman & Campbell, 1971), and the nature of aphasia (Efron, 1963c).

The systematic difference between objective and subjective simultaneity of a pair of stimuli can be indexed by the physical time difference necessary for the pair to appear simultaneous, or for the two possible orders to be reported with equal frequency. This *constant error* is usually attributed to differences between the times taken by signals representing the two stimuli to arrive at the place in the brain where their order is judged. These *arrival latencies* reflect detection and transmission delays that are not compensated for in perception and that may vary with attributes of the stimuli such as their intensities.

Arrival latencies must have some variability, which would limit the precision of temporal-order judgments (TOJs). (By "precision" we mean the sensitivity of judgment probabilities to changes in the interstimulus interval.) One of the reasons for an interest in the TOJ in its own right rather than only as a measure of mean latency differences, however, is the possibility that for many stimulus combinations, the precision of TOJs is controlled and limited primarily by variability of a central mechanism, rather than by variability within particular sensory channels (for example, Hirsh & Sherrick, 1961; Kristofferson, 1963).

#### A. EXPERIMENTAL PARADIGM

Much of this paper is concerned with experiments that use variations of the TOJ paradigm shown in Fig. 1. The stimuli are  $S_x$ , presented at time  $t_x$ , and  $S_y$ , presented at time  $t_y$ . From trial to trial the time difference  $t_y - t_x = d(x, y)$  takes on various values that can be positive, zero, or negative. After each presentation the subject judges whether  $S_x$  appeared to occur before  $S_y$  (response " $t_x < t_y$ ") or after  $S_y$ .<sup>2</sup> In this way a psychometric function  $F(d)$  is generated, in which the probability of the judgment that  $S_x$  preceded  $S_y$  increases monotonically with  $d$  over a range from zero to one.

It is convenient to regard  $F(d)$  as the (cumulative) distribution function of a random variable,  $\mathbf{D}(x, y)$ , defined such that

$$F(d) \equiv \Pr\{t_x < t_y \mid d(x, y) = d\} \equiv \Pr\{\mathbf{D}(x, y) \leq d\}. \quad (1)$$

[We shall show in Section II how  $\mathbf{D}(x, y)$  may be usefully represented in terms of other variables.] Two parameters of  $F(d)$  are usually of interest.

---

<sup>2</sup>In terms of traditional psychophysics this is the "method of single stimuli," the "stimulus" on each trial being the time interval  $d(x, y)$ .

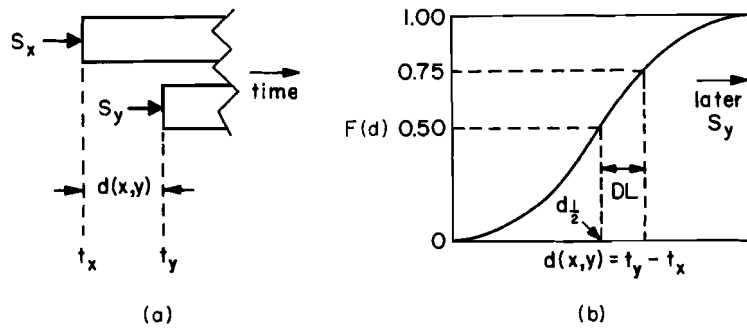

**Fig. 1.** Stimulus presentation and idealized data from a temporal-order experiment. (a) On each trial stimuli  $S_x$  and  $S_y$  are presented at times  $t_x$  and  $t_y$  to sensory channels  $x$  and  $y$ , respectively; the subject judges which stimulus appeared to occur first. Time proceeds from left to right. Rectangles indicate stimulus processing by channels; their left edges represent stimulus-presentation times. (b) Psychometric function relating  $d$ , the stimulation-time difference, to  $F(d) \equiv \Pr\{t_x < t_y \mid d(x,y) = d\}$ , the probability that  $S_x$  appears to occur before  $S_y$ .

One is the *point of subjective simultaneity* (PSS), often taken to be the 50% point: the value of  $d(x,y) = d_{1/2}$  such that  $F(d_{1/2}) = \frac{1}{2}$  and the two possible TOJs are equally likely.<sup>3</sup> [The quantity  $d_{1/2}$  is the median of the  $\mathbf{D}$  distribution; it will later be useful to consider the mean  $d_\mu = E(\mathbf{D})$  as an alternative measure of the simultaneity point.] In general, the PSS differs from the *point of objective simultaneity* ( $d = 0$ ). A second parameter of  $F(d)$  is an index of its slope, such as the *difference threshold* [ $DL \equiv \frac{1}{2}(d_{3/4} - d_{1/4})$ ], which can be regarded as half of the interquartile range of  $\mathbf{D}$ —a measure of its dispersion. The greater the precision of judgment, or temporal resolution, the smaller is the DL. (The probability of a *correct* TOJ for a particular  $d$ -value is not a useful characterization of performance in this kind of experiment, because it depends on both the PSS and the precision of judgment; see Section X,E.)

## B. EVIDENCE FOR A CENTRAL TIMING MECHANISM

One source of evidence for a central mechanism that controls the precision of TOJs is Hirsh's seminal research of a decade ago (Hirsh, 1959;

<sup>3</sup>It is worth noting that under this definition stimuli at the PSS need not necessarily give rise to a perception of simultaneity. If the required judgment was of simultaneity *versus* successiveness, rather than of one order *versus* the other, it is possible (but not necessary) that  $\Pr\{\text{"simultaneous"}\}$  would be maximized for the  $d$  value that produced maximum uncertainty about order. It is also possible that for a particular stimulus pair no  $d$  value would make  $\Pr\{\text{"simultaneous"}\}$  large.

Hirsh & Sherrick, 1961). These remarkable experiments showed that, with few exceptions, stimulus pairs from the same sensory modality—auditory, visual, or tactile—or from any of the three possible modality pairs give rise to TOJs of approximately the same precision. In most cases a DL  $\approx 18$  msec was observed. An increase in  $d$  of about 80 msec produced a change from a reliable perception of  $S_y$  first [ $F(d) \approx 0$ ] to a reliable perception of  $S_x$  first [ $F(d) \approx 1$ ]. Hirsh has stressed the fact that the time separation required to resolve two identical stimuli as successive, which shows large intersensory differences as conventionally measured, is far smaller than this  $d$ -value difference.

Some aspects of Hirsh's findings now appear to depend on details of his method (see Section X), but it is fair to say that his conclusion still stands that, with few exceptions, variations in modalities and attributes of the stimuli in a pair have relatively small effects on the precision of judgments of their temporal order. This led Hirsh to conclude that the precision is limited primarily by a central mechanism serving several modalities, rather than by the sensory channels themselves.

The exceptions we know of—cases where the order of stimulus pairs with substantially smaller separations can be reliably discriminated—seem to be attributable to special modality-specific mechanisms in which stimuli interact close to the periphery, thereby generating special cues correlated with their temporal order.<sup>4</sup> In these cases higher centers receive signals representing the *relation* of the two stimuli, rather than only *separate* representations of the stimuli themselves. These exceptions suggest that in experiments addressed to study of the conjectured central mechanism, pairs of stimuli from different modalities should be used, to insure against contamination by peripheral sensory interactions.

---

<sup>4</sup>One interesting example arises when two clicks are delivered to different ears. When the time separation is small enough ( $\leq 2$  msec, approximately) so that a fused image is perceived, the location of the image in the head depends on temporal order; under these conditions order can be reliably discriminated with time separations as small as .1 msec (Green & Henning, 1969). Because the lateralization of dichotic clicks depends on their being close in time, the lateralization phenomenon would cause the psychometric function for temporal order to be nonmonotone, rising steeply near zero and then falling before rising again when  $d \approx 15$  msec (Babkoff & Sutton, 1963). Such nonmonotone functions have also been observed for pairs of monaural clicks, with minima at about  $10 \text{ msec} < d < 15 \text{ msec}$ , and used as evidence for the existence of peripheral stimulus interactions which presumably influence the perceived quality of the composite stimulus (Babkoff & Sutton, 1971). Nonmonotone functions raise questions about the usefulness of a concept of "temporal acuity" (White & Lichtenstein, 1963). For other examples that suggest special mechanisms, see Liberman *et al.* (1961), Békésy (1963), Békésy (1969), Biederman-Thorson *et al.* (1971), and Green (1971).

Several other kinds of evidence, in addition to Hirsh's, have been adduced for a central timing mechanism. For example, Cheatham and White have shown that regardless of sensory modality, the maximum rate at which judged numerosity increases with the duration of fast trains of identical pulsed stimuli is approximately the same (see White, 1963).<sup>5</sup> Eijkman and Vendrik (1965) showed that duration discrimination of filled intervals is no better when the interval is defined by two concurrent stimuli in different sensory modalities than when it is defined by a single stimulus; if a large proportion of the judgmental variability resulted from "noise" that was associated with independent sensory channels rather than with a central mechanism, one would expect averaging in the two-stimulus condition to increase discriminability. Kristofferson (1967b) has found a strong relation between the half-periods of subjects' alpha rhythms and their ability to discriminate temporal differences between bisensory stimulus pairs.

A common view is that for the time relation between two signals to be judged, their representations must be brought together somewhere in the brain. Efron (1963a, b) and Corwin and Boynton (1968) have argued from their data that there is a common "simultaneity center" for all stimulus pairs, possibly located in the dominant hemisphere. This view develops the idea of a central mechanism one step further—from a common process to one that also has a common locus.

What might limit the time resolution of a central mechanism? One possible explanation is that attention cannot be divided between sensory channels, and that during any one time period, information from only one channel can be admitted. Exact time information for signals that arrive on unattended channels would be lost. Together with assumed constraints on when attention can be switched from one channel to another, these ideas form the basis of Kristofferson's (1963, 1967a, b, 1970, this volume) account of successiveness discrimination and several other phenomena.

A second explanation of limited time resolution is that for the central processor, time is quantized into periodic samples, or perceptual "moments" (Stroud, 1955). Signals arriving at the central processor through different channels can always be admitted, but if they arrive during the same moment their order cannot be discriminated.

Although the search for a central timing mechanism has motivated some of the workers in this area, others have used the measurement of temporal-order perception as a tool in the study of individual sensory

---

<sup>5</sup>Recently, however, John (1971) has raised some questions about the interpretation of these studies, based partly on his demonstration of the dependence of auditory-numerosity judgments on stimulus intensity.

systems, in particular, to measure variations in sensory latency. This work has focused mainly on changes induced in the PSS by changes in one of the stimuli, which are taken to reflect corresponding changes in its arrival latency. Most of it has not been concerned with the DL and the question of temporal resolution. But Rutschmann and Baron have tested the idea that the central mechanism has perfect resolution, and that order discrimination is imperfect solely because of the variability of sensory arrival times (Baron, 1969; Gibbon & Rutschmann, 1969; Rutschmann & Link, 1964; Rutschmann, 1967, 1969).

The independent-channels model that we shall be discussing in much of this paper is a generalization of all the models of order perception we know of, and permits variability both in the channels and in the central mechanism. One of our goals in the present paper is to explore two issues in light of this general model. First, how can we use TOJs to answer questions about the channels, while making minimal commitment to a model of the central decision mechanism? Second, how can we use TOJs to answer questions about the decision mechanism, with minimal assumptions about the channels?

## II. Independent-Channels Model

### A. THE GENERAL MODEL

Many of the models of TOJs that have been proposed explicitly or assumed implicitly are special cases of the general *independent-channels model* shown in Fig. 2. Stimuli  $S_x$  and  $S_y$  are presented at times  $t_x$  and  $t_y$ , where  $t_y = t_x + d$ . After an *arrival latency*, represented by the random variable  $\mathbf{R}_x$ , stimulus  $S_x$  has been detected, and a signal has been transmitted to an appropriate place in the brain, its *arrival time* being  $U_x = \mathbf{R}_x + t_x$ . The same is true for stimulus  $S_y$ ; because  $S_y$  is presented at time  $t_x + d$ , its arrival time is given by  $U_y = \mathbf{R}_y + t_y = \mathbf{R}_y + t_x + d$ . The detection and transmission operations are performed by the relevant sensory channel; arrival latencies depend on stimulus attributes and possibly also on adjustable detection criteria. The TOJ depends on the *arrival-time difference*  $U_y - U_x = \mathbf{R}_y - \mathbf{R}_x + d$ , according to some *decision rule*. Stimulus attributes and the value of  $d$  do not influence the decision directly, but only indirectly by virtue of their effects on the arrival times. The decision rule induces a *decision function*  $G$  on values of  $U_y - U_x$ , associating an order-decision probability with each arrival-time difference such that for any value of  $d$ ,

$$\Pr\{t_x < t_y \mid U_x = U_x, U_y = U_y\} \equiv G(U_y - U_x). \quad (2)$$



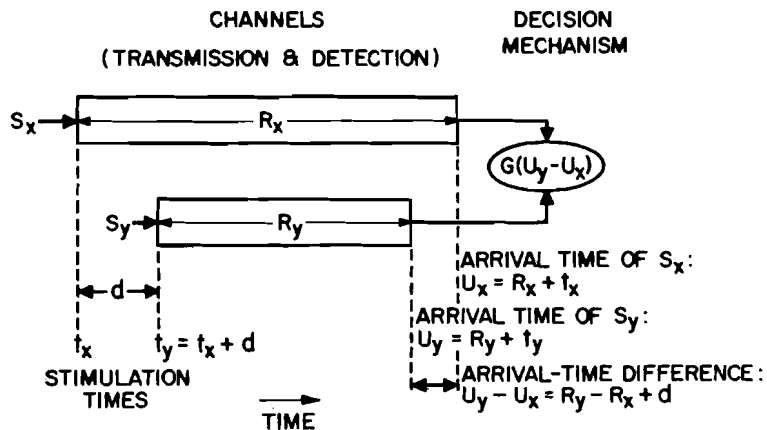

Fig. 2. Independent-channels model. Stimulus times are represented by positions of the left sides of the two boxes on a left-right time axis. Lengths of the boxes represent arrival latencies, that is, duration of the sensory transmission and detection processes on which the decision mechanism depends. The positions of the right sides represent arrival times used by the decision mechanism.

It follows that

$$F(d) \equiv \Pr\{t_x < t_y \mid d(x, y) = d\} = E[G(U_y - U_x) \mid d(x, y) = d], \quad (3)$$

where the expectation is taken over the joint distribution of  $U_x$  and  $U_y$ . We assume that  $G$  is a nondecreasing function of the arrival-time difference; this seems to exclude only those unusual cases (Section I, B) where different decision mechanisms operate at different parts of the  $U_y - U_x$  range.

The sensory channels are assumed to be separate, or independent, in the sense that activity in one channel is not influenced by *what* activity occurs in the other, or by *when* it occurs. Thus, neither  $R_x$  nor  $R_y$  is influenced by the value of  $d$ , and a change in one (resulting, for example, from a change in attributes of one stimulus) has no influence on the other. One implication is that  $R_x$  and  $R_y$  are *independent in mean*: changes in one have no direct influence on the mean of the other. Given no spurious correlation of  $R_x$  and  $R_y$  (which might be caused, for example, by overall fluctuations in sensitivity or by spontaneous fluctuations in the direction of attention), it also follows that  $R_x$  and  $R_y$  are *stochastically independent*.<sup>6</sup> (The inferences made in all the studies we know of in which the PSS is used to measure effects of stimulus variations on sensory latency require the assumption of independence in

<sup>6</sup>Since the first kind of independence can occur without the second, it is desirable to consider them separately, just as in the case of the additive durations of processing stages (Sternberg, 1969a).

mean. They also require an *assumption of selective influence* of stimuli on channels: changes in  $S_x$  influence only  $\mathbf{R}_x$  and not  $\mathbf{R}_y$ .)

We have deliberately avoided a precise definition of “channels,” since it is not yet clear what definition would be most useful. One criterion might be the independence property of the general model: two stimuli would be associated with different channels if their arrival latencies are independent. (Channels probably would not then be identified with sensory modalities.) Such a criterion should be distinguished from one based on attentional selectivity, such as Kristofferson’s (1967a), where stimuli are associated with different channels if and only if they cannot be attended to simultaneously.

#### B. ADDITIVE REPRESENTATION OF THE PSYCHOMETRIC FUNCTION FOR THE DETERMINISTIC DECISION RULE

According to the *deterministic decision rule*, the subject reports  $S_x$  before  $S_y$  if and only if the  $S_x$  signal arrives at the decision mechanism before the  $S_y$  signal. The decision function is the step function

$$G(U_y - U_x) \equiv \begin{cases} 0, & U_y - U_x < 0 \\ 1, & U_y - U_x \geq 0. \end{cases} \quad (4)$$

The discrimination of *arrival times* is thus perfect and unbiased; the limited precision of order judgments arises solely from variability of  $\mathbf{R}_x$  and  $\mathbf{R}_y$ . This model has been used extensively by Rutschmann (for example, this volume) and by Baron (1969). From Eq. (3) and definition (4) it follows that

$$\begin{aligned} F(d) &= \Pr\{0 \leq U_y - U_x \mid d(x, y) = d\} \\ &= \Pr\{0 \leq \mathbf{R}_y - \mathbf{R}_x + d\}. \end{aligned}$$

Using Eq. (1) we can express the psychometric function  $F$ —the distribution function of  $\mathbf{D}(x, y)$ —in terms of  $\mathbf{R}_x$  and  $\mathbf{R}_y$ :

$$F(d) \equiv \Pr\{\mathbf{D}(x, y) \leq d\} = \Pr\{\mathbf{R}_x - \mathbf{R}_y \leq d\}. \quad (5)$$

This relation permits us to define the following additive representation of  $\mathbf{D}(x, y)$ :

$$\mathbf{D}(x, y) = \mathbf{R}_x - \mathbf{R}_y. \quad (6)$$

In short, the psychometric function is identical with the distribution function of the arrival-latency difference between channels.<sup>7</sup>

<sup>7</sup>This relation was used by Rutschmann and Link (1964) and Gibbon and Rutschmann (1969). The generalization to an arbitrary criterion  $\beta$  on the arrival-time difference is straightforward: if “ $t_x < t_y$ ” requires  $U_y - U_x \geq \beta$ , then Eq. (6) becomes  $\mathbf{D}(x, y) = \mathbf{R}_x - \mathbf{R}_y + \beta$ .

## C. SIX MODELS OF THE DECISION MECHANISM

*Model 1.* The deterministic decision rule discussed above is only one of many interesting rules for converting arrival-time differences into responses. Six decision functions  $G$ , corresponding to six different decision rules, are shown in Fig. 3.

*Model 2.* In one variety of *perceptual-moment* theory (Stroud, 1955), time is partitioned into nonoverlapping equal intervals (moments), and two arrivals can be ordered by the decision mechanism only if they fall in different moments. The stimulus pair is assumed to occur at random relative to the phase of the moment train. The probability that a boundary between moments falls between the arrivals increases linearly with the arrival-time difference, up to the duration  $\tau$  of one moment. If  $|U_y - U_x| > \tau$ , discrimination is guaranteed, regardless of phase. If we assume that when both arrivals occur during the same moment the two order judgments are equiprobable, the result is a linear decision function that is symmetric about zero (Fig. 3b).

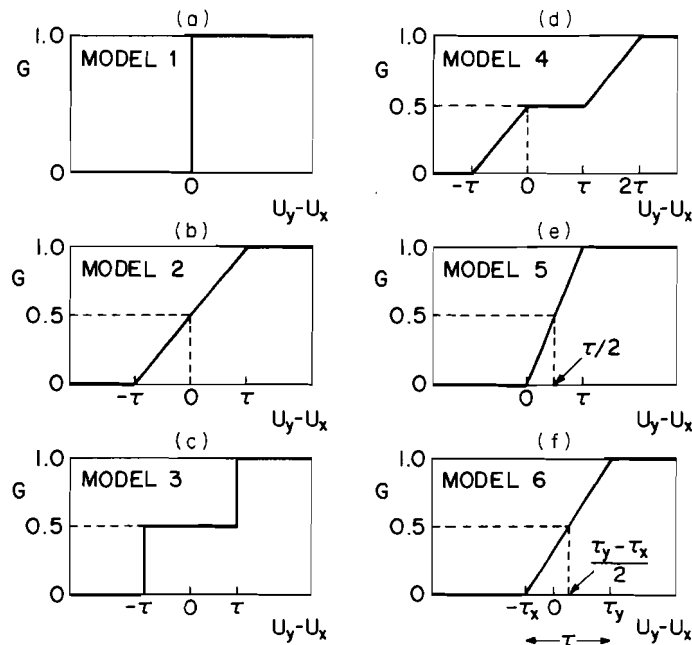

**Fig. 3.** Decision functions produced by six models of the decision mechanism. (a) Deterministic-decision model. (b) Perceptual-moment model with moment of duration  $\tau$ . (c) Threshold model with threshold of size  $\tau$ . (d) Triggered attention-switching model with three states, potential switching points separated by time  $\tau$ , and attention initially biased toward channel  $y$ . (e) Triggered attention-switching model with four states, and attention initially biased toward channel  $y$ . (f) Periodic-sampling model with period  $\tau = \tau_x + \tau_y$ . For any model, the psychometric function depends on the arrival-latency distributions as well as the decision function.

*Model 3.* The function shown in Fig. 3c is produced when a *threshold* of size  $\tau$  is applied to the arrival-time difference. If  $|U_y - U_x| < \tau$ , there is no discrimination and the two judgments are equiprobable.<sup>8</sup> Such a decision function has been considered by Baron (1970, 1971), and also arises from a *triggered moment* process, in which a moment of duration  $\tau$  is initiated by the first signal to arrive (Venables, 1960; Oatley, Robertson, & Scanlan, 1969; Mollon, 1969).

*Model 4.* Although it was developed for a different experimental paradigm, Kristofferson's (1963, 1970) *triggered attention-switching* theory can be applied here also. This theory applies to pairs of stimuli that cannot be simultaneously selected by attention; the decision function it generates is shown in Fig. 3d, for the case where attention is initially directed to channel  $y$ . (For initial attention to channel  $x$ , the function is displaced to the left by an amount  $\tau$ .) An attentional switch is triggered by the first signal to arrive, whichever it is, but switches can be accomplished only at a series of periodic time points with period  $\tau$ . Here we assume that the switch occurs at the first such time point after the arrival. A signal *registers* only when it has arrived *and* attention is switched to its channel. For order to be discriminated, attention must be switched to each channel in turn, and the signal that registers second must arrive with some delay after attention switches to its channel. If the second registration occurs without an interval between attention switching and signal arrival, then, regardless of the registration order, the same state (perceived simultaneity) is produced, and the two TOJs are equiprobable. According to this theory, then, the pattern of registrations is partitioned into three distinguishable states. Note that this is the first decision function we have considered that is not symmetric about  $U_y - U_x = 0$ .

*Model 5.* In a *four-state triggered attention-switching* theory—a variant of Kristofferson's theory not discussed elsewhere—the judgment is the same as the registration order, whether or not the second registration occurs with an interval between attention switching and signal arrival. Figure 3e shows the resulting decision function, when attention is initially directed to channel  $y$ . Although linear, like the function generated by a perceptual moment mechanism, this function is not symmetric about zero.

---

<sup>8</sup>This model and some of the others can be naturally elaborated by permitting variations in "response bias" or "criterion bias" parameters. In this instance, for example, the judgment probability associated with below-threshold arrival-time differences could be an adjustable response-bias parameter. (See footnote 7 for a way to introduce criterion bias in the deterministic rule.) In the present paper the specific models are presented primarily as illustrative, and will not be elaborated in this way.

*Model 6.* In the final model we consider (which also is not discussed elsewhere as a basis for order judgments), the sensory channels are subject to a continual *periodic sampling* process with a fixed period. Sampling may be limited to the two channels defined by the task  $(\dots, x, y, x, y, x, \dots)$ , or may include other channels as well. Arrivals at the decision mechanism are assumed to occur at random relative to the phase of the sampling process. The arrival of a signal is registered as soon as its channel is sampled; the judged order of two signals is the same as their registration order. The location of the resulting linear decision function depends on the time  $\tau_x$  from the  $y$ - to  $x$ -sampling points, and the time  $\tau_y$  from the  $x$ - to  $y$ -sampling points, as shown in Fig. 3f.<sup>9</sup> The slope of the function is governed by the period  $\tau = \tau_x + \tau_y$  of the process.

#### D. ADDITIVE REPRESENTATION OF THE PSYCHOMETRIC FUNCTION FOR THE GENERAL MODEL

For the deterministic decision rule we arrived at an additive representation of the psychometric function in terms of the arrival-latency distributions [Eq. (6)]. Here we show how this result can be extended to the probabilistic decision functions exemplified by Models 2–6.

Let  $G$  represent a general decision-function—any function of arrival-time difference that is continuous, nondecreasing, and has a range from 0 to 1. All the decision functions of Fig. 3 are special cases of this one. Because of its properties,  $G$  can be regarded as a distribution function. Define  $\Delta(x, y)$  to be the random variable that corresponds to  $G$ :

$$G(v) \equiv \Pr\{\Delta(x, y) \leq v\}. \quad (7)$$

From Eq. (3) and definition (7) it follows that

$$F(d) = E[\Pr\{\Delta(x, y) \leq U_y - U_x \mid U_x, U_y, d(x, y) = d\}],$$

where the expectation is taken over the joint distribution of  $U_x$  and  $U_y$ , or

$$F(d) = E[\Pr\{\Delta(x, y) \leq R_y - R_x + d \mid R_x, R_y\}], \quad (8)$$

where the expectation is taken over the joint distribution of  $R_x$  and  $R_y$ . Now,  $E_B[\Pr\{A \leq B \mid B\}] = \Pr\{A \leq B\}$ . [This can be verified by expressing the joint distribution of  $A$  and  $B$  as the product  $f(A \mid B)g(B)$ , where  $f$  and  $g$  are density functions, and expressing the expectation as an integral.] From Eq. (8) we therefore have

<sup>9</sup>An alternative interpretation of the same model involves sampling intervals rather than sampling points, and identifies  $\tau_x$  and  $\tau_y$  as “dwell times” on the channels of  $S_x$  and  $S_y$ , respectively, of a periodic attentional switching process limited to these channels.

$$F(d) = \Pr\{\Delta(x, y) \leq \mathbf{R}_y - \mathbf{R}_x + d\}.$$

Using Eq. (1) and rearranging terms, we arrive at an expression for the psychometric function  $F$ —the distribution of  $\mathbf{D}(x, y)$ —in terms of  $\mathbf{R}_x$ ,  $\mathbf{R}_y$ , and  $\Delta(x, y)$ :

$$F(d) \equiv \Pr\{\mathbf{D}(x, y) \leq d\} = \Pr\{\mathbf{R}_x - \mathbf{R}_y + \Delta(x, y) \leq d\}. \quad (9)$$

If we now extend definition (7) to make  $\Delta(x, y)$  stochastically independent of  $\mathbf{R}_x - \mathbf{R}_y$ , Eq. (9) permits us to define the following additive representation of  $\mathbf{D}(x, y)$ :

$$\mathbf{D}(x, y) = \mathbf{R}_x - \mathbf{R}_y + \Delta(x, y). \quad (10)$$

In short, the psychometric function for the general independent-channels model, which gives the probability of a particular TOJ as a function of  $d$ , can be expressed as the convolution of the decision function with the distribution of arrival-latency differences between channels.<sup>10</sup> This simple but powerful implication of the general model, expressed in Eqs. (9) and (10), forms the basis of much of the remainder of this paper.

The formulation in Eq. (10) makes it clear that the shape of the psychometric function  $F(d)$  depends on both  $\Delta$  (the decision mechanism) and  $\mathbf{R}_x - \mathbf{R}_y$  (the channels). [Thus, measuring the shape of  $F(d)$  will not permit rejection of any hypothesis about the central mechanism without *some* restrictions on  $\mathbf{R}_x - \mathbf{R}_y$  being assumed.] In general, the shape will reflect most strongly whichever of the two components has the greatest variance. Two extremes are represented by the theories of Rutschmann and Kristofferson. In Rutschmann's theory (for example, Rutschmann, this volume),  $\Delta$  is assumed to be a constant (zero), and it is only the latency distributions that limit precision and control the shape of  $F(d)$ . On the other hand, in Kristofferson's theory (1963)  $\mathbf{R}_x - \mathbf{R}_y$  is assumed to be a constant for any particular pair of stimuli, and only the decision function is important.

---

<sup>10</sup>Some readers may find the following argument helpful in understanding the basis of Eq. (10). Consider the deterministic decision function with criterion  $\beta$ , as discussed in footnote 7. Any (nondecreasing) decision function  $G(d)$  can be represented as a probability mixture of deterministic functions with different  $\beta$  values, the mixing distribution being the decision function itself. For each value of  $\beta$ , the  $\mathbf{D}(x, y)$  distribution is obtained by translation of the  $\mathbf{R}_x - \mathbf{R}_y$  distribution by an amount  $\beta$ . Hence, the general  $\mathbf{D}(x, y)$  distribution is a probability mixture of translations of the  $\mathbf{R}_x - \mathbf{R}_y$  distribution, the mixing distribution being the distribution of  $\Delta(x, y)$ . Now a mixture of translations of a distribution is equivalent to the convolution of that distribution with the mixing distribution. Hence, to transform the  $\mathbf{R}_x - \mathbf{R}_y$  distribution into the  $\mathbf{D}(x, y)$  distribution one must add to  $\mathbf{R}_x - \mathbf{R}_y$  the independent random variable  $\Delta(x, y)$ .

Existing evidence suggests that measurable variance is contributed by both the central mechanism and the channels. The similarity of DLs for TOJs within and between various modalities (Section I,B) suggests that a common mechanism limits precision and therefore contributes variance of its own. And estimates of variance from electrophysiological measurements tend to be too small to account entirely for the DL for order (for example, Chapman, 1962; Levick & Zacks, 1970; Levick, 1972; Zacks, 1972). On the other hand, given the assumption that the central mechanism is not influenced directly by stimulus variations, the finding that intensity changes not only alter the PSS (which could occur even if  $R_x$  had zero variance) but also can produce small but systematic effects on the DL (for example, Gibbon & Rutschmann, 1969) implies that arrival-time variability plays at least some role in controlling the precision of TOJs.

At the present stage of research on order perception we feel that the primary concerns should be, first, to validate the general independent-channels model and, second, assuming its validity for particular situations, to characterize the central mechanism by determining properties of the decision function. By making specific supplementary assumptions about the distributions of  $R_x$ ,  $R_y$ , and  $\Delta$ , one could test the general model jointly with these assumptions. But failure of such a strong model need not invalidate the general model. For this reason we consider (in Sections III and V) tests of the general model that do not require strong distributional assumptions. For similar reasons we feel it is desirable to attempt inferences from  $D$  to  $\Delta$  while invoking minimal assumptions about  $R_x$  and  $R_y$ . Examples of tests requiring no assumptions about latency distributions are described in Sections VIII and IX.<sup>11</sup>

---

<sup>11</sup>One example of a general assumption that permits inferences from  $D$  to  $\Delta$  is that the distribution of  $R_x - R_y$  is strongly unimodal (Ibragimov, 1956). Most widely used distributions have this property, including normal, exponential, gamma, double exponential, logistic, uniform, and triangular distributions, and the beta distribution with nonnegative parameters. The convolution of a strongly unimodal distribution with a unimodal distribution must itself be unimodal. Hence, if the psychometric function is observed to have more than one inflection point (indicating multimodality of the  $D$  distribution), the decision function must also have more than one inflection point (corresponding to multimodality of the  $\Delta$  distribution); such an observation would thus permit rejection of Models 1, 2, 5, and 6 of Section II,C.

A second example of a general assumption is that the  $R_x - R_y$  distribution is unimodal and symmetric about its mean. (This would be true if  $R_x$  and  $R_y$  were unimodal and identically distributed.) Because the convolution of two unimodal and symmetric distributions is itself unimodal and symmetric, a unimodal  $\Delta$  distribution symmetric about its mean, as in Models 1-6, then requires the  $D$  distribution to be unimodal and symmetric about its mean.

The main technical difficulty in using measured psychometric functions in conjunction with the additive representation of Eq. (10) appears to be that whereas the psychometric function easily provides estimates of *quantiles* of the **D** distribution, such as its 50 and 75% points, the additive representation most lends itself to simple statements about the mean, variance, and higher *cumulants*<sup>12</sup> of that distribution (see Section X, F).

In the sections that follow we describe analyses of data from a variety of studies. The analyses emphasize predicted relations among means of psychometric functions, but not higher cumulants, since these are the easiest relations to test with available data. Our conclusions depend on the assumption that although PSSs from the studies we review were not explicitly intended as estimates of means, they are approximations thereof.<sup>13</sup>

### III. Comparison of Order Judgments and Reaction Times to Test the Independent-Channels Model

Historically, the reaction-time (RT) experiment emerged from studies of TOJs of bisensory stimulus pairs (Boring, 1950, Chapter 8). It was believed that latencies of the same internal events contributed in both tasks, so that one task would shed light on the other. It is therefore not surprising that in one modern approach to testing the independent-channels model, TOJs of stimulus pairs are compared to RTs of simple (detection) reactions to each stimulus.

---

(Footnote 11—*cont.*)

An inference about  $\Delta$  that requires no assumptions about the latency distributions is based on the fact that the greatest mode of a convolution of two distributions can be no greater than the greatest mode of either component. A consequence is that the maximum slope of the psychometric function provides a lower bound on the slope of a linear decision function, and on the maximum slope of any decision function.

<sup>12</sup>Cumulants are statistics of a distribution that are closely related to its moments and that are additive for sums of independent random variables (see Kendall & Stuart, 1958).

<sup>13</sup>Most studies report either 50% points of psychometric functions determined by a method of constant stimuli, or estimates derived from an up-and-down staircase procedure or a method of limits. If the psychometric function is symmetric, all three methods estimate its mean; if it is asymmetric, the estimate is biased to varying degrees away from the mean and toward the median. Our assumption would be justified if, for example, the functions were sufficiently symmetric so that the bias was small.



Unfortunately, in order to permit such tests the independent-channels model must be considerably elaborated; the tests are then not of the model alone, but of its conjunction with strong supplementary assumptions. We shall see in Section V that without this elaboration the model is nevertheless susceptible to evaluation by other methods. We discuss RT tests first, however, for historical reasons, and because they raise important questions about the concept of perceptual latency (discussed in Section IV).

Extensions of the model that underlie such tests are shown in Fig. 4. The reaction time  $T$  is assumed to be the sum of the arrival latency  $R$  that controls the TOJ and the summed duration  $M$  of the additional processing stages that lead to the reaction. Thus, in addition to Eq. (10), we have

$$T_x = R_x + M_x \quad \text{and} \quad T_y = R_y + M_y \quad (11)$$

#### A. COMPARISON OF $D(x, y)$ AND $T_x - T_y$

Tests that compare  $D(x, y)$  to  $T_x - T_y$  have been conducted for visual-auditory pairs by Rutschmann and Link (1964) and for pairs of flashes by Gibbon and Rutschmann (1969). Let us first consider the comparison of means. The general idea is that the mean arrival-latency difference that causes the PSS to differ from zero will also cause the mean RTs,  $E(T_x)$  and  $E(T_y)$ , to differ from each other by the same amount. Two assumptions underlie this expectation. First, the "final common path" for reactions to dif-

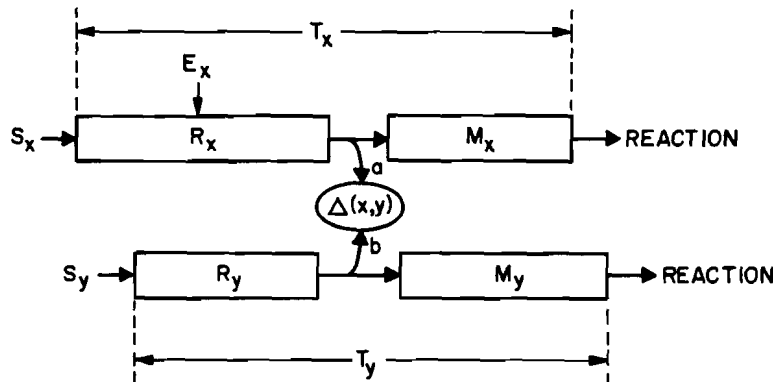

Fig. 4. Extensions of the independent-channels model that link TOJs of a stimulus pair with RTs for detection reactions to the same stimuli presented individually. The arrival time  $R$  is assumed to be an additive component of the reaction time  $T$ . The summed durations of the additional stages needed for the reaction, including "motor time," are represented by  $M$ . These additional stages are sometimes assumed to be common ( $M_x = M_y$ ). Discrepancies may force relaxation of this assumption, or insertion of additional time-consuming stages at points marked  $a$  and  $b$ . An attribute of  $S_x$ , such as its intensity  $E_x$ , is shown influencing  $R_x$  selectively.

ferent stimuli starts at the level of the order decision; that is, the inputs to a common order-decision mechanism are the same as inputs to a common response-mechanism, and

$$E(\mathbf{M}_x) = E(\mathbf{M}_y).$$

Second,  $\Delta$  is symmetric in the sense that

$$E(\Delta) = 0,$$

as in Models 1–3 of Section II,C. The result is

$$E(\mathbf{T}_x) - E(\mathbf{T}_y) = E(\mathbf{R}_x) - E(\mathbf{R}_y) = E[\mathbf{D}(x, y)] \equiv d_\mu \quad (12)$$

In the bisensory experiment of Rutschmann and Link (1964) this test failed dramatically for both subjects: whereas the auditory  $E(\mathbf{T})$  was about 45 msec shorter than the visual  $E(\mathbf{T})$ , the auditory stimulus had to be presented about 43 msec *earlier* than the visual to produce subjective simultaneity. Relative to Eq. (12) this represents a discrepancy of 88 msec. The discrepancy led to the conjecture that the order-decision mechanism was “further” (by 88 msec) from the auditory than from the visual channel; this corresponds to assuming an additional delay at point *a* or *b* of Fig. 4. An alternative explanation would relax the assumption that  $E(\mathbf{M}_x) = E(\mathbf{M}_y)$ , or the assumption that  $E(\Delta) = 0$ . In the flash-pair experiment of Gibbon and Rutschmann (1969), one of the two subjects showed a similar but smaller systematic discrepancy,<sup>14</sup> the other subject showing good agreement.

We turn now from the comparison of means to the comparison of distributions. This comparison (which also was made in both the studies cited above) tests a stronger extension of the model, involving the following further restrictions on the conditions that led to Eq. (12):

$$\Delta = 0 \quad \text{and} \quad \mathbf{M}_x = \mathbf{M}_y = M \text{ (a constant)}. \quad (13)$$

The first condition is equivalent to assuming the deterministic decision rule

<sup>14</sup>Let  $S_f$  be the foveal flash (left eye) and  $S_p$  be the peripheral flash (right eye). For this subject  $E(\mathbf{T}_f) - E(\mathbf{T}_p) - E[\mathbf{D}(f, p)] \simeq 20$  msec, approximately independent of intensity variations in  $S_f$ . This discrepancy led Gibbon and Rutschmann (1969) to elaborate the deterministic model as in footnote 7, introducing a fixed nonzero criterion on the arrival-time difference.

The considerations that apply to such discrepancies apply also to findings like those of Halliday and Mingay (1964), who compared the difference between latency estimates of the cortical evoked potentials elicited by tactile stimulation of toe and finger to an estimate of the PSS for the same pair of stimuli, in an attempt to understand the effects of the length of conduction pathways on perceived simultaneity.

(Model 1 of Section II,C). The second asserts that all the variance in RT is due to variability in the arrival latency. The consequence is

$$D(x, y) = T_x - T_y. \quad (14)$$

Thus, the empirical distribution function of RT differences is compared to the psychometric function. One remarkable outcome of the Gibbon and Rutschmann study is that even where these two functions differed in central tendency they agreed roughly in slope, supporting the implication from Eq. (14) that

$$\text{Var}(D) = \text{Var}(T_x) + \text{Var}(T_y). \quad (15)$$

It should be noted, however, that Eq. (15) does not require conditions (13), but only that  $\text{Var}(\Delta) = \text{Var}(M_x) + \text{Var}(M_y)$ .

#### B. COMPARISON OF CHANGES IN $D(x, y)$ AND $T_x$ : EQUALITY OF FACTOR EFFECTS

We see, then, that comparisons of  $D$  with  $T_x - T_y$ , even when restricted to their means, require assumptions about  $M_x$ ,  $M_y$ , and  $\Delta$  (and delays at points  $a$  and  $b$  of Fig. 4) that may be unacceptable. The failures of these comparisons suggest that either this set of supplementary assumptions, or the independent-channels model itself, is invalid. An alternative approach that links TOJs with RTs replaces the supplementary assumptions above by an *assumption of selective influence* (Sternberg, 1969b). Let  $E_x$  denote an experimentally varied attribute of  $S_x$ , such as its intensity. Assume that factor  $E_x$  influences  $R_x$  only—that it has no effect on  $R_y$  or  $\Delta(x, y)$  in the TOJ, and no effect on  $M_x$  in the RT. The only other constraint needed is that  $R$  and  $M$  are stochastically independent.<sup>15</sup>

Given these assumptions, then roughly speaking any change in  $E_x$  should cause the same change in  $T_x$  as in  $D(x, y)$ . That is, the effects of factor  $E_x$  on  $T_x$  and  $D(x, y)$  should be equal. Let  $D, D'$  and  $T_x, T_x'$  represent TOJs and RTs for  $E_x$  and  $E_x'$ , respectively. Then

$$D - D' = T_x - T_x'. \quad (16)$$

Let  $\kappa_r$  represent the  $r$ th cumulant of a random variable ( $\kappa_1$  representing the

<sup>15</sup>If this constraint is not fully satisfied, and  $R$  and  $M$  are independent in mean only, then Eqs. (16) and (17) are limited to means only.

mean,  $\kappa_2$  the variance, and so forth). Equation (16) implies the equality of  $E_x$ -effects on all cumulants:

$$\kappa_r(\mathbf{D}) - \kappa_r(\mathbf{D}') = \kappa_r(\mathbf{T}_x) - \kappa_r(\mathbf{T}_x'), \quad r = 1, 2, \dots \quad (17)$$

Thus, for example, a change in the PSS (measured by  $d_\mu$ ) induced by a change in the intensity of  $S_x$  should be the same as the change it induces in the mean RT.

There are surprisingly few studies in which both  $\mathbf{D}$  and  $\mathbf{T}$  have been examined for the same stimuli over a range of intensities.<sup>16</sup> A few tests of this kind have succeeded, the study of Roufs (1963) being perhaps the most convincing example. Roufs used onsets of 400-msec flashes, whose intensity varied over a range of two log units. He found good agreement between the effects of intensity on the PSS relative to a reference flash, and on the mean RT; both changed by about 35 msec.<sup>17</sup>

But there are several striking failures of such comparisons. In one study by Rutschmann (1967), where the stimuli were brief shocks to the two hands, an increase in stimulus intensity that reduced both  $E(\mathbf{T})$  and  $\text{Var}(\mathbf{T})$  had no systematic effect on the DL and had either no effect or an effect in the opposite direction on the PSS.<sup>18</sup> Sanford (1971) had subjects judge the position assumed by a rotating pointer when they detected an intensity increment of from 2 dB to 18 dB in a white noise, and also measured RTs to the same increments. Whereas the mean RT was shortened by 82 msec over this intensity range, the mean PSS changed by only 48 msec (in the appropriate direction, however).

In evaluating these apparent failures of the independent-channels model, it is important to consider the question of which RT procedure is the appropriate one, in terms of percentage of catch trials, amount of reward for speed, degree of signal uncertainty, randomized versus blocked inten-

<sup>16</sup>Numerous studies have been made of visual latency, some using TOJs and others using RT measures. Unfortunately, few studies have used both, and whereas the flashes in RT studies have usually been long, those in TOJ studies have tended to be brief. This difference may be partly responsible for the fact that the RT studies tend to reveal the larger intensity effects (see Section IV).

<sup>17</sup>In their comparison of the distribution functions of  $\mathbf{T}_x - \mathbf{T}_y$  and  $\mathbf{D}(x, y)$ , Gibbon and Rutschmann (1969) used three different flash intensities, permitting comparison of interquartile ranges (related to variances) as well as 50% points or medians (approximations to means). Intensity-induced changes in medians were approximately the same, with a slight tendency for larger changes in the RT data. Changes in interquartile ranges were smaller when derived from the RT data than when observed in the psychometric function.

<sup>18</sup>One possible source of these puzzling findings might be stimulus interactions associated with the bilaterally symmetric cutaneous stimuli (Rutschmann, 1967). In our terms, this would mean that the two stimuli were not associated with independent channels.

sities, and the like. It has been demonstrated convincingly, at least for auditory stimuli, that the size of the intensity effect depends on such procedural variations (for example, John, 1967; Grice, 1968; Murray, 1970). Since the judgment of order requires discrimination of one stimulus from the other, the appropriateness of simple RT might be questioned. (In one promising procedure that avoids some of the difficulties in the common comparisons, an RT measurement and an order judgment are obtained on the same trial.) Finally, to assume that stimulus intensity has no effect on  $M$ , that is, on stages that follow the order decision, is quite possibly an error. (If  $M$ , as well as  $R$ , were reduced by increases in stimulus intensity, we would have one explanation for a larger effect of intensity on RT than on  $d_{\mu}$ .) But it is hard to see how the most dramatic failures could be traced to issues like these. Instead one has to consider the concept of perceptual latency itself.<sup>19</sup>

#### IV. The Concept of Perceptual Latency

Much of the thinking about perception of temporal order and its relation to RT seems to incorporate two implicit assumptions: first, that the relevant internal representation of a temporally punctate stimulus event is itself punctate, and second, that the system is noiseless. Both assumptions are questionable.

Difficulties for the first assumption arise from the fact that at any level at which temporal summation occurs, that is, at which a lower-level response is integrated over time to any extent, abrupt changes in stimulus amplitude do not produce correspondingly rapid changes in response amplitude (Levinson, 1968; Sperling & Sondhi, 1968). This is also true for a system containing multiple paths that vary in transmission rate, if the internal response is provided by the sum of their outputs (Raab, 1962).

---

<sup>19</sup>A different kind of application of the extended independent-channels model of Fig. 4 has been made by Bertelson and Tisseyre (1969) in their attempt to determine the level of processing that mediates the effect of the frequency of a word on the mean latency,  $E(T_x) = \bar{T}_x$ , of its identification. In terms of Fig. 4, they started with the assumption that reducing word frequency causes  $\bar{T}_x$  to increase. They found from TOJs that it did not cause  $\bar{R}_x$  to increase, and inferred that it increases only  $\bar{M}_x$ , that is, that it slows only those stages that are "above" the level at which order decisions are made. One possibility that must be considered in relation to such an application is that the stimulus feature of a flashed word that is used in judging the time of the flash may not be involved in the process that ascertains the identity of the word; if so,  $\bar{R}_x$  would be unrelated to  $\bar{T}_x$ , rather than being one of its components.

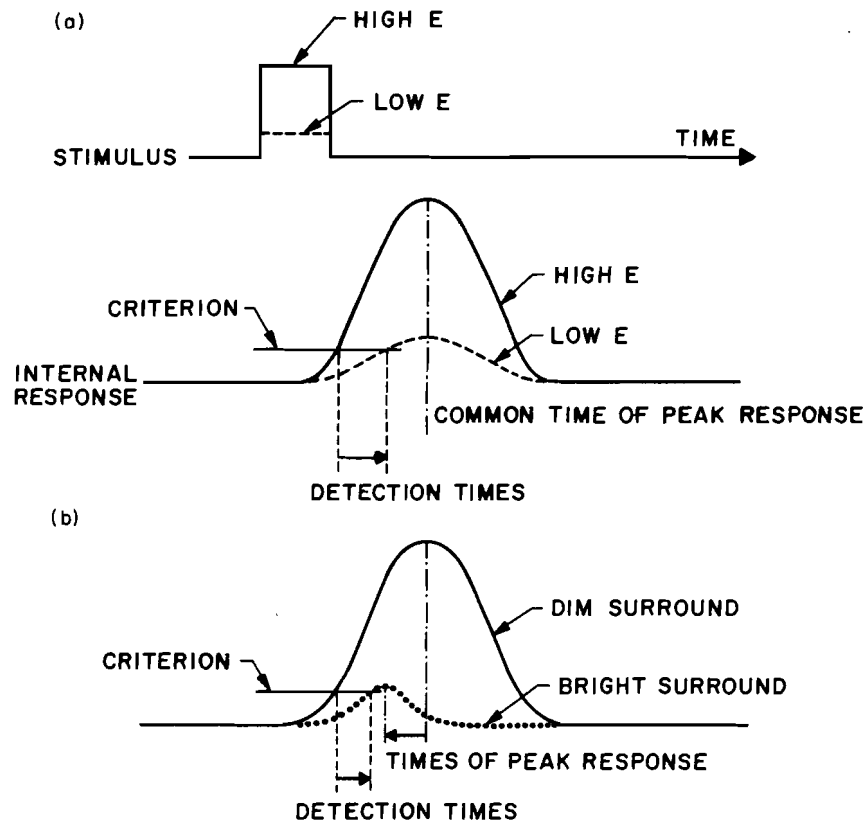

Fig. 5. Hypothetical internal responses to pulsed stimuli—here, light flashes. (a) Pulses of different intensities have different detection latencies relative to a criterion above baseline, but the same latencies to peak response. (b) Brighter annular surround reduces response amplitude, thereby prolonging detection latency, but also increases temporal resolution, thereby shortening latency of peak response.

In Fig. 5a are shown the responses that pulsed stimuli of two intensities would produce in a simple linear system with properties of a low-pass filter. The response to the more intense stimulus is simply a multiple of the response to the weaker one; thus, both responses start rising from the base line and reach their peaks at the same time. If the second implicit assumption were true—if the system were noiseless—then the initial departure from baseline could be used as a detection criterion. But in the presence of internal noise, a higher criterion (such as the one shown in the figure) is needed in order to reduce the frequency of false alarms. The particular criterion used influences not only the absolute detection latency, but also the change in latency induced by a given intensity change.

In general, unless two responses are identical in size and shape, differing by a time translation only, there *is* no uniquely defined latency difference:

the expected effect on latency of a factor such as intensity will depend on what particular feature or measure of the internal response is assumed to define its latency (see Mollon & Krauskopf, 1972). The idea of an adjustable criterion (sensitive to payoffs and instructions) applied to a temporally dispersed response has received support from a number of studies of simple RT (for example, John, 1967; Grice, 1968; Murray, 1970).

Now, it is quite possible that one feature of the internal response might be used for initiating the reaction in an RT task, and a quite different feature might serve as the time marker in a TOJ. After all, the RT task requires speed with a low false-alarm rate; whereas the TOJ requires low variance to maximize precision. Thus, TOJs might depend on the estimated time of the *peak* response, which might have less sampling variance than the delay before a response first exceeds a criterion level, because the latter, but not the former, varies with trial-to-trial fluctuations in sensitivity. In the example of Fig. 5a the peak latency is invariant, even though the detection latency changes with intensity.

A more dramatic example is shown in Fig. 5b. Suppose a brief flash is presented inside a steady annular surround. (In Section V we consider results from an experiment of this kind.) An increase in surround intensity has two effects (Alpern, 1968): it shortens the time constant of the visual system, increasing temporal resolution, and it lowers the sensitivity of the system, reducing response amplitude. It is thus possible for change in a single factor (surround intensity) to prolong the detection latency but shorten the latency of the peak.

Given such considerations, it is remarkable that RT and TOJ results ever agree. If the two measures can depend on different features of the internal response, quantitative and even qualitative disagreements do not appear critical for the independent-channels model. Relative to pulsed stimuli, onsets or offsets may provide fewer alternative features of the internal response on which order judgments might be based. This may account for the good agreement found by Roufs (1963) between effects of intensity on RTs and PSSs for light onsets in the middle range of intensities.

## V. Additive-Factor Tests of the Independent-Channels Model

### A. SELECTIVE INFLUENCE OF FACTORS ON CHANNELS: ADDITIVITY OF FACTOR EFFECTS

It seems, then, that in order to understand the relation between TOJ and RT, one needs an explicit description of the internal response and how these two tasks depend on it. Lacking such a description, how can one test

the independent-channels model? One set of consequences of the model that can be used for testing it without leaving the domain of TOJs depends on extending the assumption of selective influence mentioned in Section III,B.

Suppose there are experimental factors,  $A$  and  $B$ , that can reasonably be assumed to influence selectively the pair of channels  $x$  and  $y$  in a TOJ experiment. (For example, factor  $A$  might be the intensity of an auditory stimulus, and factor  $B$  the intensity of a visual stimulus.) The assumption means that  $\mathbf{R}_x = \mathbf{R}_x(A)$  depends on the level of  $A$  but not  $B$ ,  $\mathbf{R}_y = \mathbf{R}_y(B)$  depends on the level of  $B$  but not  $A$ , and  $\Delta$  depends on neither. Now consider  $\mathbf{D}$  (representing the psychometric function) as a function of  $A$  and  $B$ :

$$\mathbf{D}(A, B) = \mathbf{R}_x(A) - \mathbf{R}_y(B) + \Delta. \quad (18)$$

Because the arrival latencies are represented additively in Eq. (18), the assumption of selective influence implies that the factor effects are additive. That is, the change produced in  $\mathbf{D}$  by a change in factor  $A$  from one level to another is the same, regardless of the level of factor  $B$ . If  $\mathbf{R}_x$  and  $\mathbf{R}_y$  are independent in mean only, this implication applies to the PSS,  $E(\mathbf{D})$ , only; if they are stochastically independent, it applies to the variance and all the higher cumulants as well. In Sections V,B and V,C we consider experiments that test such implications.

It is important to note that in using TOJs to measure the effect of any factor on perceptual latency, one implicitly accepts the validity of both the selective influence assumption and the independent-channels model. Note also that the conclusions concerning additivity of factor effects hold, whatever the decision function,  $\Delta(x, y)$ .

## B. TESTS OF FACTOR ADDITIVITY IN THREE VISUAL EXPERIMENTS

Despite the importance of factor additivity for testing any independent-channels model, as well as for justifying many applications of TOJs, few studies have used factorial designs that permit the desired tests of additivity; fewer still were designed explicitly for this purpose, and those that do exist are restricted to measures of central tendency. In this section we discuss results of three such studies, all using pairs of visual stimuli.

The data shown in Fig. 6 are derived from a study by Efron (1963b) in which the stimuli were brief dichoptic flashes to different visual hemifields. For each subject, PSSs were estimated by a method of limits for each of the four conditions obtained by factorial combination of two left-flash ( $S_L$ ) intensities and two right-flash ( $S_R$ ) intensities. For each stimulus, the intensity



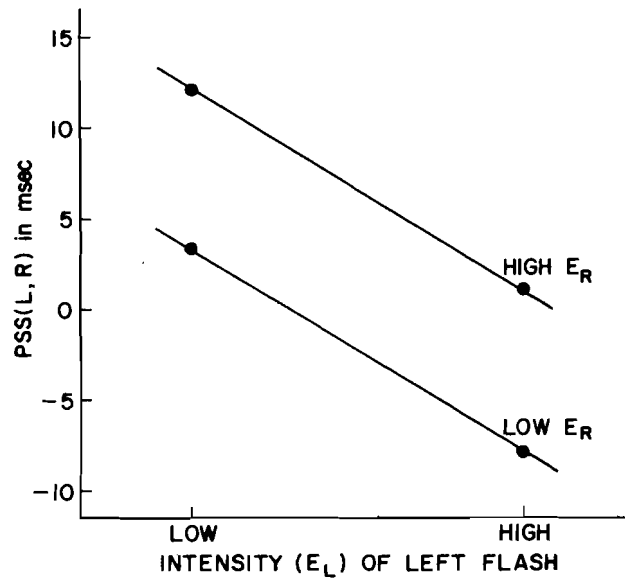

**Fig. 6.** Means over 20 subjects of the PSSs from four pairs of flash intensities in Efron's (1963b) experiment. On the abscissa are indicated the two intensities ( $E_L$ ) of the flash to the left visual field ( $S_L$ ); the parameter is the intensity ( $E_R$ ) of the right flash ( $S_R$ ). The PSS represents  $t_R - t_L$ . Also shown is the best-fitting pair of parallel lines, which represent perfect additivity of the effects of  $E_L$  and  $E_R$  on the PSS. The mean deviation of points from lines is  $.06 \pm .21$  msec; the standard error (SE) is based on the 1-*df* difference between mean deviations for right-handed and left-handed subject subgroups, regarded as sampling error.

levels were separated by one log unit. The additive model fits very well.<sup>20</sup>

Factor additivity can also be tested with data from a recent study by Matteson (1970). An annular surround was presented continuously to the right eye, above the fixation point. Subjects judged the order of a brief test flash ( $S_x$ ) inside the annulus and a brief reference flash ( $S_y$ ) presented to the other eye below the fixation point. One factor was the intensity of  $S_y$ : an increase of 2.2 log units increased the PSS =  $t_y - t_x$  by 56 msec, indicating a reduction in the latency  $R_y$ . The second factor was intensity of the test-flash surround: an increase of about 5 log units decreased the PSS by 50 msec, indicating a reduction in the test-flash latency  $R_x$ .

Matteson's surround-intensity effect is a dramatic instance of a TOJ effect in the opposite direction from what one would expect for RTs, and is

<sup>20</sup>Some caution is called for in interpreting this result. Interaction contrasts (Sternberg, 1969a, Section 5.2) for left- and right-handed subject groups were of opposite sign, resulting in a small mean contrast with a relatively large standard error (SE). The value of the SE implies that a mean interaction contrast of as much as 2.7 msec (31% of the smaller main effect) would be needed to reach significance at the .05 level.

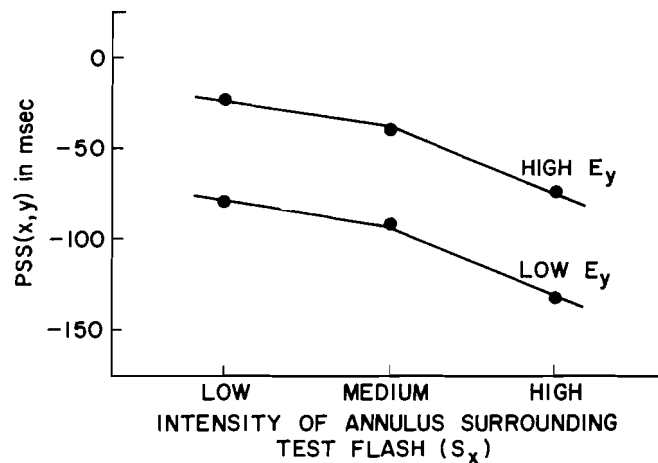

Fig. 7. Means over two subjects of the PSSs from six combinations of reference-flash ( $S_y$ ) and test-flash ( $S_x$ ) surround intensities in Matteson's (1970) Experiment II. On the abscissa are indicated three sets of surround intensities; the parameter is the intensity ( $E_y$ ) of the reference flash. The PSS represents  $t_y - t_x$ . Also shown is the best-fitting pair of parallel profiles, which represent perfect additivity of the effects on the PSS of the two factors. The mean absolute deviation of points from lines is 1.3 msec. (See footnote 22.)

consistent with the analysis diagrammed in Fig. 5b.<sup>21</sup> Mean PSSs from two subjects, obtained by a staircase procedure, are shown in Fig. 7. Again, an additive model fits well.<sup>22</sup>

In our third example, however, we find clear-cut interactions when we apply what seem to be similar tests. Rutschmann (contribution to this volume, Experiment II) factorially varied the intensities of a dichoptic foveal-peripheral flash pair, using the method of constant stimuli to measure PSSs.

<sup>21</sup>In accordance with that analysis, a later study by Matteson, Lewis, and Dunlap (1971) has shown that the effect disappears or is markedly reduced when the onset of a long flash, rather than a pulse, is being judged. Presumably, the early flank of the internal response is likely to be more salient (relative to any early peak) when the stimulus is a long flash than when it is a pulse, and therefore is more likely to be the latency-defining feature for TOJs.

<sup>22</sup>There were actually seven levels of surround intensity; for purposes of the present analysis they were combined into three sets. Again, in this instance, the exceptional goodness of fit for the mean data should be interpreted with caution, because they represent the sum of two (nonsignificant) interactions in opposite directions for the two subjects. To express this idea quantitatively, we need an estimate of the precision of a measure of the mean interaction. To arrive at such an estimate, consider the linear component of the interaction, which can be expressed as a 1-*df* signed quantity for each subject simply by fitting an additive model to low- and high-intensity surrounds only. Whereas the mean data then show a mean deviation from additivity of only .6 msec, the SE of this quantity, based on the 1-*df* between-subject difference, is 3.8 msec.

The effects of the two factors did not add: peripheral intensity had a larger effect on the PSS when foveal intensity was high than when it was low. (See Section X,B for a possible explanation.)

### C. ADDITIVE-FACTOR TEST OF AN INDEPENDENT-CHANNELS MODEL OF BINAURAL LATERALIZATION

When dichotic clicks are presented with a time separation of no more than about 2 msec, a fused auditory image is formed, located inside the head. Changes in time separation cause changes in perceived location within the head; the separation that causes the fused image to be centered can be regarded as a PSS. Furthermore, in terms of its perceived location, increasing the intensity of one of the clicks is equivalent to presenting it earlier.

Binaural lateralization is of interest in relation to temporal-order perception for several reasons. First, it seems to depend on a special peripheral mechanism that has much better resolution than that observed in most temporal-order experiments (see footnote 4). Second, and more important for our present purpose, lateralization provides an instructive testing ground for the independent-channels model, where the model is extended from order judgments to another perceptual domain in which it is thought that the relative arrival time of a pair of signals is critical in determining the percept. Finally, the relation between effects of intensity on lateralization and on TOJs outside the lateralization region exemplifies relations that may be useful in tracing information flow in sensory systems, as described in Section V, D.

An explicit independent-channels theory of lateralization was developed by both David, Guttman, and van Bergeijk (1958) and Deatherage and Hirsh (1959):

...the binaural lateralization mechanism, located at some point where the outputs from the two ears converge, is sensitive to time difference only. Under this hypothesis binaural intensity difference at the ears is converted to time difference according to the time-intensity trading relation [David *et al.*, 1958].

In our terms, click intensities influence the channels selectively and have only indirect effects on the decision mechanism, mediated by the changes they induce in arrival latencies. David *et al.* (1959) recognized and used the implication expressed in Eq. (18) that effects of intensity on the PSS would be additive, but never tested it. A subset of the data from the Deatherage and

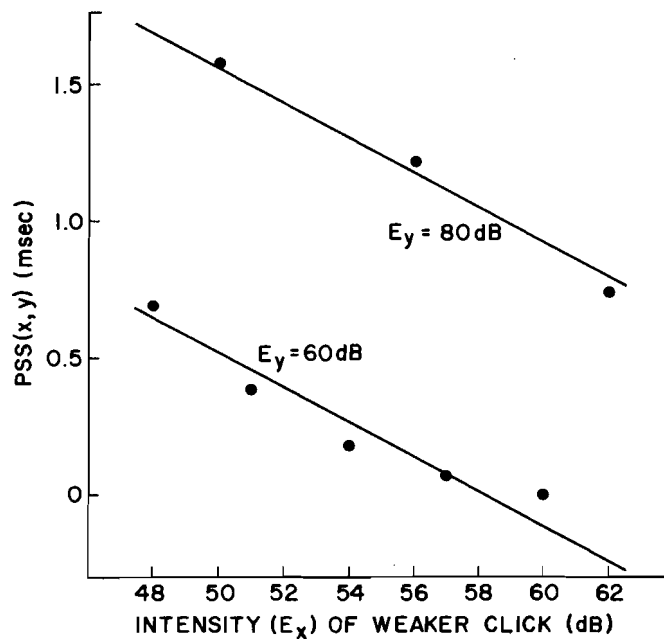

**Fig. 8.** Data suitable for additivity test selected from the Deatherage and Hirsh (1959) experiment on auditory localization. The points are derived from four observers' data. Each point represents an average of values from two conditions: stronger click to right ear, stronger click to left ear. The intensity ( $E_x$ ) of the weaker click in peak-equivalent sound pressure level is indicated on the abscissa; the parameter is the intensity ( $E_y$ ) of the stronger click. The PSS is the amount  $t_y - t_x$  by which the weaker click was advanced relative to the stronger, to "center" the fused image in the head. Parallel quadratic functions fitted to this subset of the data had a negligible quadratic component; therefore, perfect additivity of the effects of  $E_x$  and  $E_y$  on the PSS is represented by parallel lines.

Hirsh (1959) study, however, provides an approximation to an appropriate factorial design; results of the test, which we regard as promising for the independent-channels model, are shown in Fig. 8.<sup>23</sup>

Such additivity would support not only the general model, but also the assumption of selective influence, and thus help justify using the effect of intensity on a PSS to measure an effect of intensity on latency in the sensory channel. Interpreted this way, the "time-intensity trade" in lateraliz-

<sup>23</sup>Because variability in this study was reported as being "rather large," and information about the precision of individual data points is no longer available, the deviations from the fitted functions are difficult to evaluate quantitatively.

For comments on some of the complexities of binaural lateralization that might lead one to question the applicability of the independent-channels model, see Green and Henning (1969). One complication is that experienced observers are able to report on two separate fused images produced by dichotic signals, each image having its own time-intensity trading relation (Hafters & Jeffress, 1968).

ation implies a very small effect of intensity on latency. For moderate intensities in the Deatherage and Hirsh study the effect is on the order of .05 msec/dB. We know of no studies of the effect of intensity on the PSS for exactly comparable auditory stimuli outside the fusion region, where temporal order is judged. But the studies that come closest (Hirsh, 1959, Experiment IV; Sanford, 1971) reveal an effect of intensity on auditory latency that is one or two orders of magnitude greater. This difference suggests that some of the interesting features of sensory channels might be represented by the model shown in Fig. 9.

#### D. USE OF THE TIME-INTENSITY TRADING RELATION TO TRACE INFORMATION FLOW

Figure 9 shows each channel performing a series of processing operations on the input, with the durations of more than one of the early processes influenced by stimulus intensity. Furthermore, these processes are all influenced in the same direction: the higher the intensity, the shorter their durations.<sup>24</sup> In the figure, for example, both  $R_x$  and  $R_{x'}$  are shortened by an increase in  $E_x$ . Since the arrival latency at  $\Delta$  is  $R_x$ , whereas the arrival latency at  $\Delta'$  is  $R_x + R_{x'}$ , the intensity effect on a PSS mediated by  $\Delta'$  will be the greater. In other words, the effect of intensity on the latency of a signal is augmented as it passes through the channel. This implies that for any decision mechanisms that operate on arrival-time differences, the more processing required to produce their inputs, the greater the effect of intensity on the PSS. Given the results discussed in Section V,C—a smaller effect of intensity on PSS in binaural lateralization than in temporal order—this

---

<sup>24</sup>This could occur if higher intensity caused the output of a process to have both shorter latency and greater amplitude, and if greater amplitude of the input to the next process shortened its duration. Note that in a strict sense, such processes are not "stages" (Sternberg, 1969a, Sec. 3.2), because relevant features of their outputs are not independent of factors influencing their durations. The possibility of such indirect effects of intensity on later processes is supported by electrophysiological evidence (Miller & Glickstein, 1967; Miller, Moody, & Stebbins, 1969). It is also consistent with findings that intensity can have larger effects on RTs than on TOJs (Section III,B) or on latencies of visually evoked cortical responses (Vaughan, *et al.*, 1966). For the visual system, however, the possibility of intensity effects on durations of higher processes conflicts with the common notion that there is just one locus of the effect of intensity on latency (Bernhard, 1940; Prestrude, 1971; Stevens, 1970) and that processing stages at levels above the retina contribute latency components that are independent of stimulus intensity. An error in interpreting latency-intensity functions is sometimes made when functions that are parallel on a logarithmic time scale (such as power functions with equal exponents, which may differ by a scale factor on a linear time scale) are assumed also to be parallel on a linear time scale.

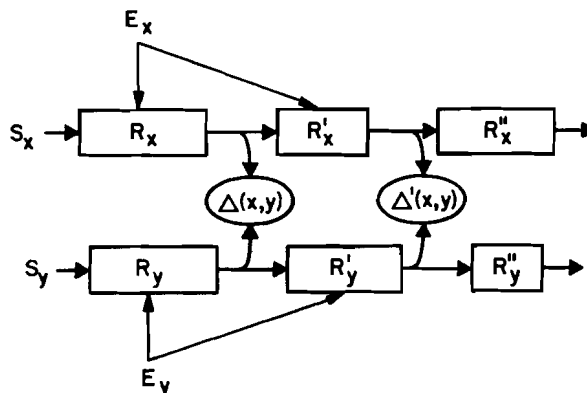

Fig. 9. Extension of the independent-channels model to judgments that depend on arrival times at different "depths" in the channel. Increasing the stimulus intensity  $E_x$  is assumed to reduce the duration  $R_x'$  as well as  $R_x$  (see footnote 24). Hence, the influence of intensity on the arrival latency  $R_x + R_x'$  at  $\Delta'$  is greater than its influence on the arrival latency  $R_x$  at  $\Delta$ . The same applies for channel  $y$ . However,  $E_x$  and  $E_y$  must have additive effects on the PSSs associated with both  $\Delta$  and  $\Delta'$ .

argument is consistent with the view that the stimulus representation used by the binaural-lateralization mechanism is available closer to the periphery than is the representation used by the temporal-order mechanism.

An equally interesting instance of different time-intensity trading relations based on different kinds of judgment arises in vision. We consider three phenomena, all involving the perceived locations of moving objects. The Pulfrich effect is an illusion of stereoscopic depth produced when an object is moved in the frontal plane and viewed binocularly with a neutral filter over one eye (Lit, 1949). Because the filter attenuates the input to one eye, it is thought to delay the arrival of signals from that eye at the place in the brain where binocular fusion occurs. The binocular signals that arrive simultaneously therefore correspond to different locations of the moving object, the spatial disparity changing with the rate and direction of movement. As in stereograms and normal binocular vision, such changes in disparity are interpreted as changes in depth. The delay can be inferred from the size of the depth effect, and measured as a function of the amount of attenuation (Lit, 1949; Alpern, 1968). With an actual moving object, one cannot separately manipulate attenuation and delay of the stimuli to the two eyes so as to nullify the depth illusion, and thereby measure the PSS more directly. But with moving stereo displays, such direct measurement of the time-intensity trading relation at the level of binocular fusion is possible. Julesz and White (1969) have made a start in this direction, and Rogers and Anstis (1972) have reported extensive measurements.

A similar phenomenon is produced when a display of two separate objects, one above the other and moving back and forth in synchrony in the

frontal plane, is viewed monocularly. When one of the objects is covered by an attenuating filter, it appears to lag behind the other (Wilson & Anstis, 1969). Here it is possible to adjust the objective lag of one movement relative to the other so as to nullify the subjective lag, thereby measuring the PSS directly, as a function of the amount of attenuation.

A third phenomenon arises when subjects attempt to align a moving dichoptic vernier display—two radial line-segments shown to different eyes while rotating at the same rate about what appears to be the same axis (Prestrude, 1971). When the display to one eye is covered by an attenuating filter the subjective alignment is disturbed; the amount of objective misalignment needed to restore it provides a measure of the PSS.

In studies of these three phenomena the effects of intensity on the PSS were smallest for the rotating dichoptic vernier, intermediate for stereoscopic depth, and greatest for correlated movement. Given a model of the kind diagrammed in Fig. 9, these differences in time-intensity trading relations would lead to the inference that stereoscopic depth is achieved higher in the visual system than vernier alignment, but lower than comparison of the positions of separated moving objects. But to justify this inference it would also have to be shown that for each phenomenon intensity effects in the two channels are additive, thereby demonstrating the validity of the independent-channels model in each instance.<sup>25</sup>

#### E. CHANNELS, STAGES, AND ADDITIVE FACTORS

The independent-channels model, the assumption of selective influence of factors on channels, and the additive representation of Eq. (18), together parallel closely considerations that arise when the reaction time  $T$  is regard-

---

<sup>25</sup>Approximate mean changes in PSSs in the three situations, in response to an increase in retinal illuminance of 1.0 to 4.0 (0 to 4.0) log trolands, are as follows:

vernier alignment (Prestrude, 1971)	23 ( 36) msec
stereoscopic depth (Lit, 1949)	32 ( — ) msec
(Rogers & Anstis, 1972)	38 ( 71) msec
correlated movement (Wilson & Anstis, 1969)	45 (121) msec

(Because no artificial pupil was used in the Wilson and Anstis experiment, the values above depend on corrections for pupil size that we have applied to their data. To estimate the larger value from Prestrude's data a small extrapolation was required.)

We have performed rough additivity tests on the four sets of data listed above; at this writing it appears that the independent-channels model is supported at least for the vernier and depth data.

From altogether different considerations, Julesz (1971, Ch. 3) has concluded that stereopsis is located higher in the visual system than monocular vernier acuity, but lower than movement perception.

ed as the sum of durations of two component processing stages of interest,  $T_a$  and  $T_b$ , and the duration of the remaining stages  $T_w$ . Along with this *stage theory*, an assumption of selective influence leads to an additive representation of  $T$  similar to Eq. (18):

$$T(A, B) = T_a(A) + T_b(B) + T_w; \quad (19)$$

the implied additivity of factor effects on  $T$  provides tests of the theory and assumption. In the *additive-factor method* (Sternberg, 1969a) one inverts the argument in the case of RT, seeking factors with additive effects and using them to infer the existence and nature of processing stages. In the same way, instances of additive and interacting factors in the domain of TOJs can be used to identify independent sensory channels, defined in the sense of Section II,A.

The similarities and contrasts between these approaches are instructive. In both, the basic theory involves additivity (arrival-latency difference, stage-duration sum), assumed selective influence, and implied additivity of factor effects. With RT, a subset of stages ( $T_a$ ,  $T_b$ ) can be studied that are embedded in unknown others ( $T_w$ ); with TOJs, a pair of channels ( $R_x$ ,  $R_y$ ) can be studied in the context of an unknown decision function. In both, independence in mean and stochastic independence can be separately assessed. The major difference, and one that creates greater technical difficulties for the study of channels, is that whereas the  $T$  distribution can be directly sampled, access to the  $D$  distribution is limited to points on its distribution function.

## VI. Prior Entry: Effect of Attentional Bias on Temporal-Order Perception

“The stimulus for which we are predisposed requires less time than a like stimulus, for which we are unprepared, to produce its full conscious effect.” This *law of prior entry* was included by Titchener (1908, p. 251) among his seven laws of attention. In our terms, the law asserts that the shifting of an attentional bias from channel  $x$  to channel  $y$  causes the  $PSS(x, y) = t_y - t_x$  to increase; we call this increase the *prior-entry effect*. The effect is promising as a tool for the study of attention. But more important for our present purpose, it provides a constraint on all theories of order perception.

Shortly after Titchener published his law, Dunlap (1910) reconsidered the experiments on which it was based, and concluded that the effects claimed for attention were actually artifacts resulting from flaws in experi-



mental method.<sup>26</sup> But a later study by Stone (1926), which avoided many of the early pitfalls, demonstrated the effect and provided a characterization that recent experiments (Sternberg, Knoll, & Gates, 1971) tend to confirm.

Stone's subjects judged the order of a tap (cutaneous) and a click (auditory). Stimulus times were determined by a method of constant stimuli. In different series of trials, subjects made judgments under two conditions of attentional bias induced by instruction (for example, "Attend to the click; expect the click."). The results, shown in Fig. 10, reveal a mean prior-entry effect of 46 msec, which is large relative to effects that are often of interest in temporal-order experiments. Furthermore, the findings hint at a characterization of the effect as a horizontal translation of the psychometric function, without systematic change in shape.

Perhaps the first question that should be asked in the context of the independent-channels model is whether the locus of the prior-entry effect is in the channels or in the decision mechanism. Some models of the central mechanism (Models 4, 5, and 6 of Section II, C, for example) are inherently responsive to attentional changes. Others (for example, Model 3) would require postulation of correlated changes in response bias (see footnote 8). On the other hand, some views of attention (see Moray, 1969) would locate the effect in the channels and, for example, identify an attentional bias toward a particular channel with an increase in sensitivity or a reduction in the level of a detection criterion for stimuli in that channel.<sup>27</sup>

The additive representation of the general model, given in Eq. (10), suggests one way of answering the question of locus. Let  $E_x$  and  $E_y$  represent intensities of stimuli  $S_x$  and  $S_y$ , respectively, and let  $B$  represent an attentional-bias factor. Suppose that  $B$  influences the decision mechanism only. Then, considering  $D$  as a function of  $E_x$ ,  $E_y$ , and  $B$ , we have

$$D(E_x, E_y, B) = R_x(E_x) - R_y(E_y) + \Delta(B). \quad (20)$$

The implication, as in Section V, A, is that effects of all three factors will be

---

<sup>26</sup>The experiments on which the law was based—"complication" experiments—were modeled after the astronomers' problem of determining when a star crossed a hairline (visual) in relation to a series of clicks (auditory). Most of them involved multiple observations of a continuously rotating pointer and a discrete acoustic stimulus, with the observer judging the position the pointer assumed when he heard the sound. Dunlap argued that the effects attributed to attention resulted from variations in the eye movements associated with the moving pointer, and found fault with the use of multiple presentations before each judgment.

<sup>27</sup>If this were so, the concept of perceptual latency (Section IV) would become even more troublesome, particularly since the size of an intensity effect would depend on the state of attention.

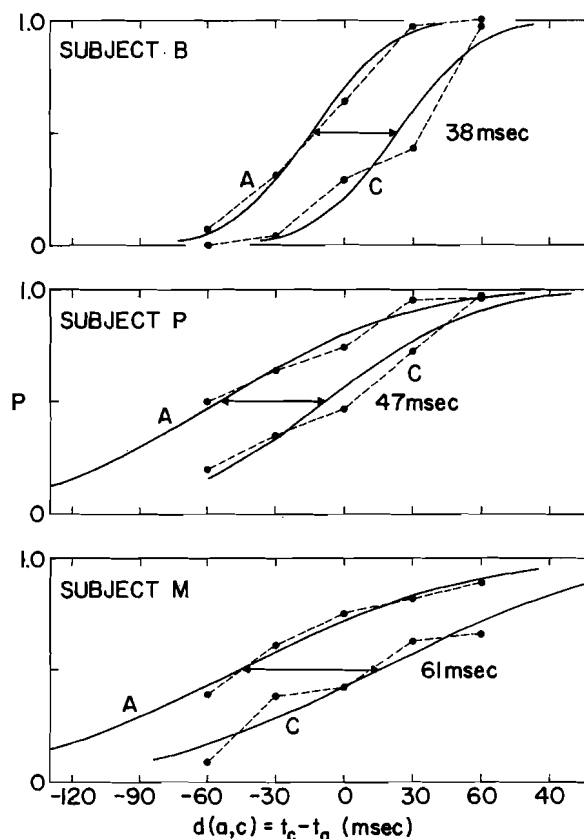

Fig. 10. Psychometric functions from Stone's (1926) experiment, with normal ogives fitted by maximum likelihood (probit analysis). Curves marked A and C represent judgments when attention was biased toward the auditory and cutaneous signals, respectively. If subjects were uncertain, they could withhold their response (" $t_a = t_c$ "); hence, the quantity plotted is  $P = \Pr\{t_a < t_c\} + \frac{1}{2} \Pr\{t_a = t_c\}$ . The DLs for conditions A and C were 19 and 20 msec, 44 and 35 msec, and 54 and 53 msec for subjects B, P, and M, respectively. Prior-entry effects, measured by differences between means of the fitted ogives, are shown.

additive. In particular, the prior-entry effect, measured as a change in the mean of the psychometric function, will be independent of stimulus intensity. But if the attention factor as well as stimulus intensity influences the channels, some interaction between effects of these factors would be expected. For example, if attentional bias is mediated by a reduced detection-criterion level (Fig. 5a), the prior-entry effect should be decreased as  $E_x$  and  $E_y$  are increased. (Figure 5a shows the higher intensity producing an internal response with a steeper slope in the criterion region. A given reduction in criterion then leads to a smaller latency reduction for a high- than for a low-intensity stimulus.)

The prior-entry effect may not be restricted to heteromodal stimulus

pairs: intramodal effects have been claimed by Needham (1936), Rubin (1938), and Ladefoged and Broadbent (1960).

The existence of the effect leads to problems of method as well as to interesting questions of theory. In almost no recent studies of order perception has there been any explicit control of attentional bias. A spontaneous fluctuation of bias would induce spurious correlation among arrival latencies, destroying stochastic independence and altering the shape of the psychometric function, although it might not interfere with independence in mean. Systematic attentional shifts that were correlated with conditions could cause the independent-channels model to fail in many ways. (If a subject is free to do so, he might bias his attention to the dimmer of two flashes if intensity is not randomized, bias it differently for onsets than offsets, or bias it in a way that depends on the earlier observations on a trial with multiple observations of the same stimulus pair, or on the first observation in a forced-choice task.) On the other hand, it seems unlikely that systematic attentional shifts would produce spurious support for the independent-channels model. This observation might tempt one to argue from the successful additivity tests of Section V,B that systematic shifts of attentional bias may not occur readily.

## VII. Potential Effects of Interchannel Interactions

We have seen that although attentional effects might make difficult the testing of the independent-channels model, they are not, in principle, incompatible with the model. In contrast, if there is interaction among the channels that process even heteromodal signals, as has been argued from the results of certain kinds of RT experiments, this would be fatal to the assumption of channel independence and thus to the general model. The possibility of such interaction arises from RT experiments where irrelevant signals closely precede or follow reaction signals. In general, preceding signals delay the response, as in studies of the "psychological refractory period" (Smith, 1967), and following signals facilitate it, as in studies of "intersensory facilitation" (for example, Bernstein, Rose, & Ashe, 1970). There also exists electrophysiological evidence for heteromodal interactions; for example, Thompson *et al.* (1963) have observed heteromodal inhibitory effects in association areas of the cat's cortex.

It is possible that these effects arise at processing stages higher up than those on which temporal-order perception depends; indeed, insofar as the independent-channels model is confirmed, such a view would gain sup-

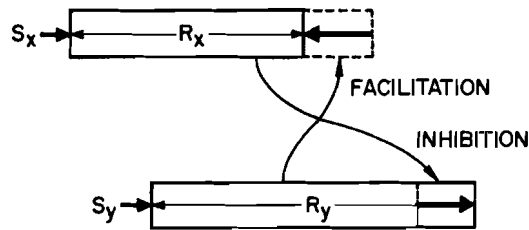

**Fig. 11.** Possible effects of interchannel interaction on the arrival-time difference. If interactions inferred from RT experiments were located in the channels, early activity in channel  $x$  might inhibit channel  $y$ , prolonging  $R_y$ , and later activity in channel  $y$  might facilitate channel  $x$ , shortening  $R_x$ . When  $d(x, y) = t_y - t_x$  was positive (negative), then,  $U_y - U_x$  would be increased (decreased), thereby improving discriminability.

port. But the possibility must be kept in mind that these phenomena arise at early processing stages, and reflect changes in the arrival latencies  $R_x$  and  $R_y$ . This would complicate the relation between the stimulation-time difference  $d(x, y)$ , and the arrival-time difference  $U_y - U_x$ , as shown in Fig. 11. Depending on their form, these interchannel interactions could sharpen temporal discrimination: the psychometric function would represent greater discriminability than the central mechanism alone could provide. Also, depending on their form, these effects could distort the function.

### VIII. Transitivity of Subjective Simultaneity and the Existence of a Common Simultaneity Center

Simultaneity in *physical* time is a *transitive relation*: if events  $a$  and  $b$  are simultaneous, and events  $b$  and  $c$  are simultaneous, then events  $a$  and  $c$  must also be simultaneous. The simultaneity point for an event pair divides possible arrangements of the pair into those that produce the two possible orders. This relation between simultaneity and order, together with the transitivity of simultaneity, implies that there can be no arrangement of events in physical time such that their order is intransitive: for all arrangements where  $a$  precedes  $b$ , and  $b$  precedes  $c$ ,  $a$  must precede  $c$ . Since physically simultaneous events are not, in general, subjectively simultaneous, the transitivity relations of events in physical time need not carry over to subjective simultaneity or subjective order.

In this section we consider the concept of transitivity of subjective simultaneity and its relation to the idea that not only does a common *mechanism* mediate TOJs of most stimulus pairs, but also that this decision

mechanism has a common *locus*—a “simultaneity center”—in the brain.<sup>28</sup> We consider some other implications of the existence of a common decision center and show that, contrary to common belief, it is neither necessary nor sufficient for transitivity. Since the issue of transitivity is nonetheless important, we review the few existing studies that are relevant to it.

#### A. TRANSITIVITY OF ARRIVAL LATENCIES AND DECISION FUNCTIONS

In considering the pairwise subjective simultaneity of several stimulus pairs we use  $PSS(x, y) \equiv d_\mu(x, y)$  to define the simultaneity point. It is convenient to regard a stimulus  $S_i$  together with its presentation time  $t_i$  as an ordered pair  $(S_i, t_i)$ . Let time values  $t_x = t_x^*$ ,  $t_y = t_y^*$ , and  $t_z = t_z^*$  be chosen to produce subjective simultaneity of  $(S_x, t_x^*)$  with  $(S_y, t_y^*)$  and of  $(S_y, t_y^*)$  with  $(S_z, t_z^*)$ . This requires  $t_y^* - t_x^* = d_\mu(x, y)$  and  $t_z^* - t_y^* = d_\mu(y, z)$ . The transitivity condition then implies simultaneity of  $(S_z, t_z^*)$  with  $(S_x, t_x^*)$ , or  $t_x^* - t_z^* = d_\mu(z, x)$ . Define

$$\mathbf{I}(x, y, z) \equiv \mathbf{D}(x, y) + \mathbf{D}(y, z) + \mathbf{D}(z, x), \quad (21)$$

and let  $\bar{\mathbf{I}} \equiv E(\mathbf{I})$ . The transitivity condition can then be expressed as

$$\bar{\mathbf{I}}(x, y, z) = d_\mu(x, y) + d_\mu(y, z) + d_\mu(z, x) = 0, \quad (22)$$

and  $\bar{\mathbf{I}}$  may be used as an index of intransitivity.<sup>29,30</sup>

Under what conditions does Eq. (22) hold? Let  $\mathbf{R}_x(y)$  be the arrival latency of signal  $S_x$  when it is being ordered relative to  $S_y$ . Then, from

<sup>28</sup>It has been argued (for example, Corwin & Boynton, 1968) that a necessary condition for the judgment of order of any pair of stimuli is that internal responses to those stimuli be brought together at some locus in the brain, by way of convergent neural pathways from each sensory area.

<sup>29</sup>Here and elsewhere in this section it is helpful to use the complementary relation among pairs of psychometric functions (and decision functions):  $\mathbf{D}(x, y)$  has the same distribution as  $-\mathbf{D}(y, x)$  [and  $\Delta(x, y)$  as  $-\Delta(y, x)$ ]. Hence  $d_\mu(x, y) = -d_\mu(y, x)$ , and similarly for  $d_{1/2}$ .

<sup>30</sup>Note that we have defined the PSS as the mean of the psychometric function  $d_\mu(x, y) = E[\mathbf{D}(x, y)]$ , and not the median. This is necessary in order to develop the theory of the present section. If simultaneity is defined instead as the 50% point, then the transitivity of subjective simultaneity becomes *weak stochastic transitivity*:  $\Pr\{t_x < t_y\} = \frac{1}{2}$  and  $\Pr\{t_y < t_z\} = \frac{1}{2}$  implies  $\Pr\{t_x < t_z\} = \frac{1}{2}$ ; the three medians, rather than the three means of Eq. (22), add to zero. Like many of the additivity properties developed earlier in this paper, the transitivity properties of the present section depend on features that the expectation does not, in general, share with the median. Hence, tests of transitivity that use the 50% points of psychometric functions are properly thought of as approximations.

Eq. (10),

$$\mathbf{D}(x, y) = \mathbf{R}_x(y) - \mathbf{R}_y(x) + \Delta(x, y). \quad (23)$$

Define

$$\mathbf{I}_R(x, y, z) \equiv [\mathbf{R}_x(y) - \mathbf{R}_x(z)] + [\mathbf{R}_y(z) - \mathbf{R}_y(x)] + [\mathbf{R}_z(x) - \mathbf{R}_z(y)], \quad (24)$$

and

$$\mathbf{I}_\Delta(x, y, z) \equiv \Delta(x, y) + \Delta(y, z) + \Delta(z, x). \quad (25)$$

Then Eqs. (21) and (23) imply that

$$\mathbf{I} = \mathbf{I}_R + \mathbf{I}_\Delta. \quad (26)$$

In general, for  $\bar{\mathbf{I}} = 0$  and transitivity, we must have both  $\bar{\mathbf{I}}_R = 0$  and  $\bar{\mathbf{I}}_\Delta = 0$ . The quantity  $\bar{\mathbf{I}}_R$  can be regarded as an index of *arrival-latency intransitivity*. If there is a common center, as diagrammed in Fig. 12a, the arrival latency of  $S_x$  is the same, whether it is ordered relative to  $S_y$  or  $S_z$ . Hence,  $\mathbf{R}_x(y) = \mathbf{R}_x(z) = \mathbf{R}_x$ , and similarly for the other channels, so that  $\bar{\mathbf{I}}_R = 0$  and the arrival latencies are transitive.

On the other hand, if the temporal order of different stimulus pairs is determined in different centers, and reached by pathways of different "lengths" (Fig. 12b), such that  $E[\mathbf{R}_x(y) - \mathbf{R}_x(z)] \neq 0$ , and so forth, then, in general,  $\bar{\mathbf{I}}_R \neq 0$ . Furthermore, suppose that  $\mathbf{R}_x(y)$  and  $\mathbf{R}_x(z)$  are differentially influenced by stimulus intensity ( $E_x$ ) as suggested in Fig. 12b. Then the amount of intransitivity  $\bar{\mathbf{I}}_R$  would depend on  $E_x$  and, conversely, the effect of  $E_x$  would depend on the stimulus,  $S_y$  or  $S_z$ , with which  $S_x$  was paired. (Note, however, that if the first process in each channel, which might represent events at the receptor level, has a long duration relative to the others, then deviations from transitivity would be small, and a precise experiment would be needed to detect them.)

That the existence of a common center is not, strictly speaking, a *necessary* condition for transitivity of arrival latencies is shown by the arrangement in Fig. 12c, in which the latency differences associated with different centers cancel each other out. To be sure, the arrangement is implausible, but the possibility should be kept in mind.

In the existing studies of transitivity (Efron, 1963a; Békésy, 1963; Corwin & Boynton, 1968), the decision rule was implicitly assumed to be deterministic and unbiased (Model 1 of Section II, C). For that model as well as Models 2 and 3,  $E[\Delta(x, y)] = 0$  and, *a fortiori*,  $\bar{\mathbf{I}}_\Delta = 0$ . Hence, a common center, implying  $\bar{\mathbf{I}}_R = 0$ , is sufficient for transitivity of PSSs [Eq. (22)].

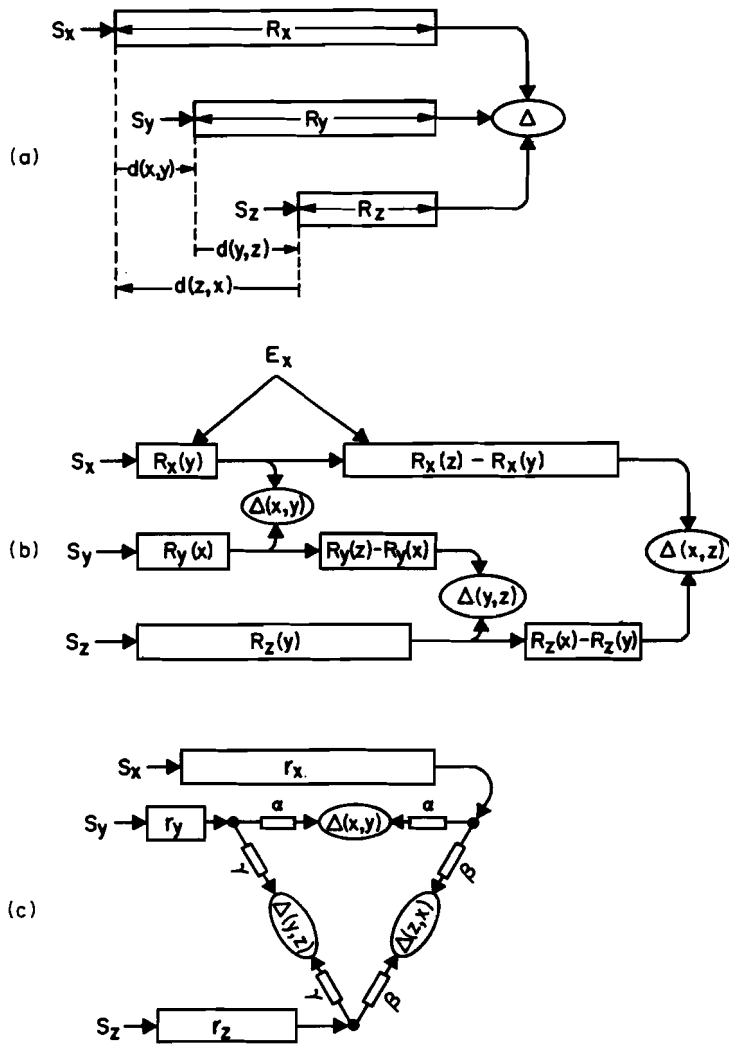

**Fig. 12.** Three arrangements of channels and decision centers. (a) Common decision center showing transitive arrival latencies, with stimulus times adjusted for simultaneous arrivals. (b) Different center for each pair of channels, reached by pathways of different "lengths" (that is, durations). Components of pathway durations are symbolized as in Eq. (24). Intensity ( $E_x$ ) of  $S_x$  is shown influencing both parts of channel  $x$ , and therefore having a larger effect on  $R_x(z)$  than on  $R_x(y)$ . In general, arrival latencies are intransitive. (c) Different centers, but with each center midway between "initial-arrival points" (large dots) of its pair of signals. The durations  $\alpha, \beta$ , and  $\gamma$  are additional delays associated with pathways between initial-arrival points and decision centers. The arrangement produces  $R_x(y) = r_x + \alpha$ ,  $R_x(z) = r_x + \beta$ , and so forth, and can be shown to give transitive arrival latencies,  $I_R = 0$ .

More generally,  $\bar{I}_\Delta$  can be regarded as an index of *decision-function intransitivity*. Because  $\bar{I}_\Delta$  may be nonzero, as in Models 4–6, the existence of a common center is not a *sufficient* condition for transitivity of PSSs.

## B. FURTHER IMPLICATIONS OF A COMMON DECISION CENTER

The properties discussed in Section VIII,A can be generalized and extended in interesting ways—to relations among higher cumulants of psychometric functions, and to sets of more than three stimuli. In this section we list some of these results without proof. Note that only one of them [Eq. (30)] is used in the analyses that follow. All except Eq. (30) require us to assume that arrival latencies are stochastically independent.

Define a symmetric decision function (exemplified by Models 1–3) as one where  $\Delta(x, y)$  has the same distribution as  $-\Delta(x, y) = \Delta(y, x)$ . All its odd cumulants are zero. For three channels with symmetric decision functions, Eq. (22), for the mean, generalizes to all odd cumulants:

$$\begin{aligned} \kappa_r[\mathbf{I}(x, y, z)] &= \kappa_r[\mathbf{D}(x, y)] + \kappa_r[\mathbf{D}(y, z)] + \kappa_r[\mathbf{D}(z, x)] = 0, \\ r &= 1, 3, \dots \end{aligned} \quad (27)$$

The condition for  $r = 3$ , for example, implies that if one of the three psychometric functions is symmetric, then the others must be either both symmetric or both asymmetric. If both are asymmetric, the asymmetries must be of opposite sign. Some of Baron's results (1970, Fig. 2) provide a successful test of this expectation.

For the even cumulants, the most we can assert is a triangle condition on  $\kappa_2$  (the variance). Assuming equal variances for the three decision functions,

$$\kappa_2[\mathbf{D}(x, y)] + \kappa_2[\mathbf{D}(y, z)] \geq \kappa_2[\mathbf{D}(z, x)]. \quad (28)$$

The triangle condition means that the sum of any two variances can be no smaller than the third.

For four (or more) channels with symmetric decision functions, paired in a simple closed chain, Eq. (27) for the odd cumulants can be generalized as follows:

$$\begin{aligned} \kappa_r[\mathbf{I}(w, x, y, z)] &= \kappa_r[\mathbf{D}(w, x)] + \kappa_r[\mathbf{D}(x, y)] + \kappa_r[\mathbf{D}(y, z)] \\ &+ \kappa_r[\mathbf{D}(z, w)] = 0, \quad r = 1, 3, \dots \end{aligned} \quad (29)$$

In particular, with or without stochastic independence,

$$\bar{\mathbf{I}}(w, x, y, z) = d_\mu(w, x) + d_\mu(x, y) + d_\mu(y, z) + d_\mu(z, w) = 0. \quad (30)$$

With four channels the constraint on the even cumulants is stronger, how-



ever. Assuming identical decision functions or, at least, functions whose even cumulants are identical:

$$\kappa_r[\mathbf{D}(w, x)] - \kappa_r[\mathbf{D}(x, y)] + \kappa_r[\mathbf{D}(y, z)] - \kappa_r[\mathbf{D}(z, w)] = 0, \\ r = 2, 4, \dots \quad (31)$$

### C. TESTS OF TRANSITIVITY IN THREE EXPERIMENTS

We know of only two experiments explicitly designed to test the transitivity of subjective simultaneity; a third did so incidentally. In all three experiments, PSSs for each stimulus pair were determined in separate series of trials by a staircase procedure or a modified method of limits. (This direct approach has a potential flaw that should be kept in mind. Insofar as attentional bias is free to vary and produce prior-entry effects, bias differences among trial series where different pairs are judged could produce spurious intransitivity. See Section X,D.)

Efron (1963a, Experiment III) used four different stimuli—dichoptic flashes to left and right fields ( $V_L, V_R$ ), and shocks to left and right index fingers ( $S_L, S_R$ ), of a single subject. PSSs for all six possible pairs were estimated. (This is a desirable procedure since it permits four separate tests<sup>31</sup> of transitivity, with 3 *df*.) Results are summarized in Table 1. For each test, the stimuli are identified with  $S_x, S_y$ , and  $S_z$  in such a way that  $d_\mu(z, x)$  differs in sign from the other two PSSs and is negative. When this is done, the deviations from transitivity (represented by the sums of three PSSs in the last column) appear to be small but systematic.<sup>32,33</sup>

Corwin and Boynton (1968) tested transitivity among pairs drawn from

<sup>31</sup>The appropriate test is to fit a single additive model to all six PSSs, estimating three parameters that represent mean arrival-latency differences and using the remaining 3 *df* for testing. Such a model accounts for 91% of the variance among the PSSs in Efron's data, and the deviations fail to reach significance at the .05 level. But for clarity, and to display the systematic nature of the deviations, we present results of separate transitivity tests based on the four subsets of three stimuli.

<sup>32</sup>The SE of the intransitivity index is based on the pooled variance (54 *df*) of the ten observations entering into each PSS.

<sup>33</sup>Discrepancies in the direction shown could occur if estimates from the method of limits were sensitive to starting values of  $d$ . If mean starting values were approximately the same for the six stimulus pairs, and the subject was reluctant to change his judgment either very early or very late in a series, then PSS estimates would be biased toward being close to each other in absolute value. A better method of revealing a pattern of discrepancies of this kind would be to let  $d_\mu(z, x)$  in Table 1 correspond to the PSS that is largest in a fitted additive model (footnote 31), rather than letting it equal the observed PSS that differs in sign from the others, as we did. For these data the two methods give identical results.

**Table 1.** *Transitivity Test from Efron (1963a)<sup>a</sup>*

$S_x$	$S_y$	$S_z$	$\hat{d}_\mu(x, y)$	$\hat{d}_\mu(y, z)$	$\hat{d}_\mu(z, x)$	Intransitivity
$V_L$	$V_R$	$S_L$	9.75	13.25	-17.25	$5.75 \pm 2.03$
$V_L$	$V_R$	$S_R$	9.77	11.25	-18.00	$3.02 \pm 2.03$
$V_L$	$S_L$	$S_R$	17.25	2.50	-18.00	$1.75 \pm 2.03$
$V_R$	$S_L$	$S_R$	13.25	2.50	-11.25	$4.50 \pm 2.03$

<sup>a</sup>Data from one subject; values in milliseconds.

**Table 2.** *Transitivity Test from Corwin and Boynton (1968)<sup>a</sup>*

Subject	$S_x$	$S_y$	$S_z$	$\hat{d}_\mu(x, y)$	$\hat{d}_\mu(y, z)$	$\hat{d}_\mu(z, x)$	Intransitivity
CS	N	E	F	21.7	37.3	-47.0	$12.0 \pm 8.2$
RF	N	E	F	-0.7	25.7	-43.0	$-18.0 \pm 8.7$
RMB	N	F	E	50.0	15.0	-65.0	$0.0 \pm 9.3$

<sup>a</sup>Data from three subjects; values in milliseconds.

three visual stimuli: monocularly viewed brief flashes to the fovea (F), above the fovea (N), and to the right (E). The results are summarized in Table 2, where the conventions are as in Table 1.<sup>34</sup> The deviations from transitivity are neither significant nor systematic in this experiment, but a more precise test is probably called for.

Interesting within-modality transitivity tests have also been reported by Békésy (1963) as "control measurements" in studies of the effects of conduction-pathway lengths on the perception of pairs of nearly simultaneous tactile stimuli. The experimenter selected three sites on the body at different distances from the brain, and applied tactile stimuli to the three possible pairs of sites. The PSS for a pair was defined as the time difference needed to localize the sensation midway between the two sites; Békésy argued that this occurred when arrival times at the brain were equal. Unfortunately, no data from these tests were reported, so it is difficult to evaluate Békésy's conclusion that the PSSs were approximately transitive.

An extensive study that provides perhaps the most convincing answer to a question of transitivity was conducted for a different purpose by Hansteen (1968, 1971). Using a staircase procedure, he measured PSSs in an attempt to

<sup>34</sup>The SEs are based on within-subject variation among three separate estimates of each transitivity index (2 *df*).

**Table 3.** *Transitivity Test from Hansteen (1968)<sup>a</sup>*

Subject	Test-flash intensity							Intransitivity $\bar{I} = V_0 - V_1$
		$\hat{d}_\mu(c_0, t_0)$	$\hat{d}_\mu(c_1, t_0)$	$V_0$	$\hat{d}_\mu(c_0, t_1)$	$\hat{d}_\mu(c_1, t_1)$	$V_1$	
TF	High	46.2	40.6	5.6	58.3	103.8	-45.5	51.1 ± 9.6
	Low	- 4.6	- 3.0	-1.6	19.9	52.1	-32.2	30.6 ± 5.8
	H-L	50.8	43.6	—	38.4	51.7	—	—
GH	High	54.3	-46.3	100.6	110.7	74.0	36.7	63.9 ± 7.2
	Low	- 3.6	-82.0	78.4	69.4	9.4	60.0	18.4 ± 7.0
	H-L	57.9	35.7	—	41.3	64.6	—	—

<sup>a</sup>Data for foveal test stimuli; values in milliseconds. Differences  $V_0$  and  $V_1$  represent the two terms in Eq. (32).

compare the perceptual latencies of the onsets and offsets of long flashes. Since PSSs of test and comparison flashes were estimated for all four combinations of test onset ( $t_0$ ) and offset ( $t_1$ ) and comparison onset ( $c_0$ ) and offset ( $c_1$ ), the intransitivity index of Eq. (30) can be estimated. In that equation, let  $w = c_0$ ,  $x = t_0$ ,  $y = c_1$ , and  $z = t_1$ . By rearranging and using  $d_\mu(j, k) = -d_\mu(k, j)$  we obtain

$$\bar{I} = [d_\mu(c_0, t_0) - d_\mu(c_1, t_0)] - [d_\mu(c_0, t_1) - d_\mu(c_1, t_1)]. \quad (32)$$

Thus, for transitivity to hold, the difference in PSS caused by a change from comparison onset to comparison offset should be the same whether ordering is done relative to test onset or test offset. In Table 3 we present the results for foveal test stimuli (right eye, intensities 4700 and 4.7 trolands) and peripheral comparison stimuli (left eye, intensity 470 trolands). We have averaged over variations in test-stimulus background level, since this factor had virtually no effect on PSSs for foveal tests.<sup>35</sup> As shown in the last column, all four tests of transitivity fail substantially, significantly, and in the same direction. The difference would imply that the amount by which test-onset latency exceeds test-offset latency is substantially less when the reference is comparison onset than when it is comparison offset.<sup>36</sup>

<sup>35</sup>The SEs are based on residual mean squares in within-subject analyses of variance, with 11 (16) *df* for low (high) intensity. The results for peripheral tests are not summarized here because they depended on test-background intensity and are less clear-cut.

<sup>36</sup>It is possible to explain this remarkable finding as an artifact based on systematic variations in attentional bias, and consequent prior-entry effects. Assume, for example, that if only one flash is turned on before the event pair to be judged, it captures the attention, whereas if both flashes are either on or off, attention is biased toward the foveal test flash. The intransitivity index then becomes an estimate of the prior-entry effect.

#### D. PATHWAY DIFFERENCES AND THE VARIATION OF INTRANSITIVITY WITH STIMULUS INTENSITY

A second notable aspect of Hansteen's results is the substantial effect of test-flash intensity on the intransitivity index  $\bar{I}$ . If the intransitivity were due solely to decision-function intransitivity ( $\bar{I}_\Delta \neq 0$ ) such an effect could not occur: given a common center, the effects of  $E_x$  on  $\mathbf{R}_x(y)$  and  $\mathbf{R}_x(z)$  would be equal and  $\bar{I}_R$  would be zero regardless of intensity. [See Eq. (24).] Instead, the existence of an intensity effect implies pathway differences like those shown in Fig. 12b. Assuming selective influence of  $E_x$  on channel  $x$ , the index  $\bar{I}_R$  can vary with  $E_x$  if and only if the effects of  $E_x$  on  $E[\mathbf{R}_x(y)]$  and  $E[\mathbf{R}_x(z)]$  differ, and this is possible if and only if the effects of  $E_x$  on  $d_\mu(x, y)$  and  $d_\mu(x, z)$  differ. Such differences are illustrated by the discrepancies within each of the two pairs of intensity effects (H-L) for each subject, given in the third and sixth rows of Table 3. When either the onset ( $t_0$ ) or the offset ( $t_1$ ) of the test flash is judged, the effect (H-L) of its intensity on the PSS depends on whether the other event is an onset or an offset.<sup>37</sup>

Since either one of these two discrepancies—for  $t_0$  or for  $t_1$ —would be sufficient to indicate pathway differences, it is not necessary to perform a full test of transitivity in order to obtain evidence bearing on the existence of a common center. In general, it is sufficient to determine whether a change in  $E_x$  has the same effect on  $\text{PSS}(x, y)$  as on  $\text{PSS}(x, z)$ , where  $S_y$  and  $S_z$  are qualitatively different stimuli that would be expected to involve different decision centers if such existed. If the effects differ, as in Hansteen's study, pathway differences can be inferred. If the effects are equal, then either the arrival pathway of  $S_x$  is the same whether  $S_x$  is ordered relative to  $S_y$  or to  $S_z$ , or there are different pathways that happen to be equally influenced by intensity.

In contrast to Hansteen's results, Roufs' (1963) study contains an interesting example of equal effects of flash intensity on the PSS relative to three different reference stimuli: the onset of a flash to the same eye, the onset of a flash to the opposite eye, and the onset of a tone. For these three reference stimuli, the linear regressions of one subject's PSSs on  $\log_e$  (retinal illuminance) had estimated slopes and 95% intervals of  $-7.6 \pm 0.3$  msec,  $-7.6 \pm 1.3$  msec, and  $-6.6 \pm 1.4$  msec, respectively. This result gives at least some support to the idea of a common decision center.

---

<sup>37</sup>Since we find an explanation in terms of different centers implausible in this instance, we are inclined to seek an alternative account. The explanation of intransitivity in this experiment in terms of attentional-bias variations (footnote 36) can be extended to cover its variation with stimulus intensity if it is assumed, for example, that where the events being judged are both offsets, the attentional bias toward the foveal flash is reduced when it is of lower intensity.

## IX. Order Judgments of Multiple Stimuli

### A. RELATION TO THEORETICAL ISSUES

Up to now we have considered perception of the order of stimulus pairs only. Additional light can be shed on several theoretical issues by studying the perceived order of three or more stimuli.

Suppose, for example, that there are pair-specific decision centers with intransitive arrival latencies, and that subjects judge the order of stimulus triples. Suppose further that the response on each trial is required to be an ordered triple, in which the ordering of the three pairs is inherently transitive. Then, for some temporal arrangements of the stimulus triple, the order information available at the pair-specific centers will be intransitive, and therefore not expressible in the response. Forcing intransitive perception to fit the mold of a transitive response could reduce the apparent perceptual precision. On the other hand, if intransitivity were produced solely by a common decision mechanism, such as Model 6 of Section II,C, the information available at the center on any individual trial would be transitive, in which case this difficulty would not arise.

Even if a common decision center is assumed, almost all models of the decision mechanism lead us to expect that to achieve a specified probability of "correct" order requires a greater separation between successive stimuli for triples than for pairs. This follows from the fact that a triple is correctly ordered only when all of its three component pairs are.<sup>38</sup> When the response is an ordered triple, the judgment of a component pair can be identified as the corresponding ordered pair embedded in the response triple. A more theoretically decisive comparison of order discrimination of pairs and triples concerns a pair in isolation versus the same pair embedded in a triple (the full response again being an ordered triple), and involves the precision of order discrimination (DL) rather than probability "correct" (which depends on both the DL and the PSS).

Insofar as the independent-channels model is applicable, embedding of a pair in a triple has no influence on arrival latencies.<sup>39</sup> For this reason, the

---

<sup>38</sup>Even if there were no variability in either arrival latencies or decision mechanism, a greater separation would be required for triples than pairs if absolute values of the three PSSs differed. For equally spaced stimulus times, the perceived order would be "correct" for each of the six possible stimulus orders only if the interstimulus interval was greater than the largest of the six PSSs (see Fig. 13).

<sup>39</sup>Note, however, that particularly if all three stimuli are in the same sensory modality, increasing the number of stimuli to be ordered increases the chance of peripheral stimulus interactions that would violate the independent-channels model.

comparison of isolated with embedded pairs holds promise for discriminating among models of the decision mechanism. Thus, for Model 1 (deterministic) or Model 2 (perceptual moment), embedding a pair in a triple should have no effect either on the discriminability of order or on the PSS. Baron (1970) has pointed out that for Model 3 (threshold), embedding could actually improve performance. (Suppose arrivals are in the order  $U_x < U_y < U_z$ , with  $U_y - U_x < \tau$  and  $U_z - U_y < \tau$ . If, however,  $U_z - U_x > \tau$ , this adds enough information for the arrival times of the entire triple, including all three pairs, to be discriminated.) For Models 4 and 5 (triggered attention-switching) embedding should reduce precision. The effect for Model 6 (periodic sampling) depends on whether the period increases with the number of channels to be sampled.

When more than two stimuli are to be ordered, it is possible not only to study the perceived order of a sequence presented once, but also to study perceived order of the same sequence presented repeatedly in a recycling fashion. Such a study might be motivated by a general interest in the perceived order of elements embedded in a stream of stimuli. An interesting consequence of differences from one stimulus to another in mean arrival latency, illustrated in Fig. 13, is that arrival orders in many-cycle and single-cycle presentations could differ systematically. This could happen if not all the arrivals associated with one cycle occurred before the first arrival from the next cycle. One difficulty in interpreting results of studies with recycled stimuli is that assumptions must be made about how information from different cycles combines to determine the final judgment.

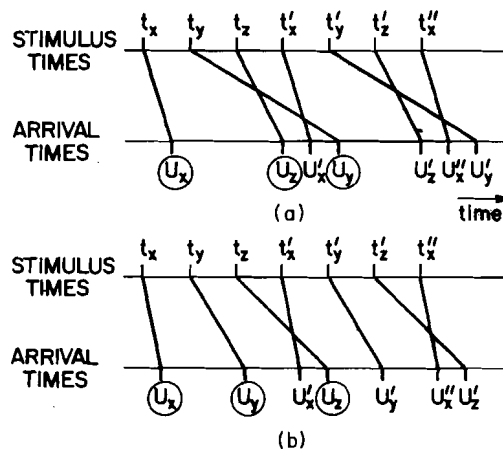

**Fig. 13.** Effects on arrival sequences of recycling stimuli with equal interstimulus times. Arrivals from a single cycle are circled. (a) Single-cycle arrival order "incorrect" while recycled arrival order "correct." (b) Single-cycle arrival order "correct" while recycled arrival order "incorrect." Range of the three arrival latencies (and therefore size of largest PSS) is larger in (a) than in (b). Hence, "correct" arrival order with single cycles of all six stimulus orders requires a larger interstimulus time for (a) than for (b).

## B. CHARACTERISTICS OF EXISTING STUDIES USING MULTIPLE STIMULI

Relatively few published studies have been concerned with the perceived order of three or more stimuli. All involve stimuli within a single sensory modality, temporal patterns restricted to equal intervals between successive stimuli, and emphasis on "correctness" rather than separate analysis of perceptual precision (DL) and perceptual "bias" (PSS). For these reasons it is difficult to interpret the finding that even when onsets of successive stimuli are separated by 100 msec or more in recycling presentations, accuracy is far from perfect (Bregman & Campbell, 1971; Pinheiro & Ptacek, 1971; Thomas, Hill, Carroll, & Garcia, 1970; R. M. Warren, Obusek, Farmer, & R. P. Warren, 1969).

We know of only one study yielding data that permit comparison of TOJs of isolated stimulus pairs with TOJs of the same pairs embedded in triples (Hill & Bliss, 1968).<sup>40</sup> Results show clearly that for a stimulus pair with a given interstimulus interval, probability of "correct" report is markedly reduced when the pair is embedded in a triple, even if elements of the pair are presented first and last in the triple. Roughly speaking, for the same degree of accuracy, an embedded pair requires two or three times as much time separation as the same pair in isolation. [For example, with 60 msec between stimulus onsets, an isolated pair was correctly ordered with probability .93; with 120 msec between the onsets of  $S_1$  and  $S_3$  in the  $S_1-S_2-S_3$  triple, the  $S_1-S_3$  pair was correctly ordered in the response triple with probability .91 (from data in Hill & Bliss, 1968, Table 5).] If a finding such as this could be extended to measures of judgmental precision other than "correctness," and under conditions less subject to the limitations mentioned in Section IX, A, it would have considerable theoretical importance.

## X. Comments on Experimental Method

In this section we assemble some of our impressions and preferences concerning experimental method in the study of temporal-order perception.

---

<sup>40</sup>This study has the virtue of using single rather than recycling presentations. A possible defect for our purposes, however, is that the stimuli presented on a trial (brief tactile stimuli on the hands, differing in location) were drawn randomly from an ensemble of 24 possible stimuli, so that identity as well as order information increased with the number of stimuli. The proportions we report here are conditional on correctness of the identity information in the response.

### A. MULTIPLE-OBSERVATION METHODS

Procedures in which subjects are permitted ad lib multiple observations before each judgment have a long history in studies of temporal-order perception. For example, they were used in the "complication" experiments of the last century (Dunlap, 1910; see footnote 26), in the experiments of Hirsh (1959) and Hirsh and Sherrick (1961), and in several of the studies of order perception of multiple stimuli mentioned in Section IX,B.

If the underlying psychometric function for single observations was strictly monotonic and did not vary from trial to trial, one would expect that ad lib observations on each trial could produce indefinitely precise discrimination, limited only by the number of observations the subject chose to make (Green & Swets, 1966, Chapter 9). Such considerations make the interpretation of results from ad lib observation procedures difficult. What is remarkable, however, is the small size of the reduction actually produced in the DL when ad lib observations are permitted (Gengel & Hirsh, 1970). One possible explanation is that memory limitations prevent subjects from making full use of multiple observations (see Section XI). They might also lead to questions about the desirability of methods that require subjects to compare one presentation to their memory of one or more others, as when a standard stimulus is presented on each trial, and as in forced-choice procedures (for example, Kristofferson, 1963; Liberman *et al.*, 1961).

### B. BIASING EFFECTS OF STIMULUS RANGE

In the context of the method of single stimuli, multiple observations may have a large effect on the PSS, forcing it closer to the center of the stimulus range than does a single-observation procedure. Such a difference between procedures was demonstrated by Gengel and Hirsh (1970). This biasing effect of stimulus range may account for the consistent finding by Hirsh (1959) and Hirsh and Sherrick (1961) that in experiments where the range was centered at zero and multiple observations were used, PSSs were very close to zero.

Even with single observations on each trial, the PSSs measured with a method of constant stimuli are somewhat suspect, particularly when the range is relatively small, because of range-induced biases (Guilford, 1954, Chapter 6; Erlebacher & Sekuler, 1971). Adaptive up-and-down "staircase" methods, in which the distribution of stimuli is automatically centered approximately at the PSS, seem to us far better for measuring the PSS (Kappauf, 1969a,b; Levitt, 1971). Data from stimulus sequences controlled by such procedures may be used to estimate the entire psychometric function as well,



but because the estimates of probabilities from those data may be subject to bias, an estimate of the function is perhaps better derived by the method of single stimuli with range centered on a previously measured PSS. It is instructive that of the three additive-factor tests using the PSS that were reviewed in Section V,B, the two that were relatively successful did not use the method of constant stimuli.

The stimulus range in the method of constant stimuli may also have an effect on the precision of TOJs (Hirsh & Fraisse, 1964).

Methodological developments associated with signal-detection theory (Green & Swets, 1966) have made it possible to eliminate effects of response bias (or decision criterion) when discriminability is being measured, by using the assumed dependence of bias (but not of discriminability) on explicit or implicit payoffs. But to answer many of the questions raised in this paper, the PSS ("constant error") must be measured. At present, though, there is no established method (such as using payoffs for "correctness") for disentangling changes in arrival-time means from changes in possible bias parameters. [Feedback and payoffs can easily cause transformations of the psychometric function that are approximately horizontal translations (Gengel & Hirsh, 1970).] The orderliness of some of the results reviewed in Section V,B, however, suggests that the problem of bias may not always be a serious one.

#### C. PURITY OF STIMULUS INFORMATION

We have already commented on the desirability of using stimuli from different sensory modalities so as to reduce the likelihood of peripheral stimulus-interactions and the special cues they might generate. For similar reasons, onsets (or offsets) are probably better than pulsed stimuli, because the internal response may be simpler, providing fewer alternative features that might be used to register time of occurrence (Section IV). (Indeed, the judged order of pulsed stimuli may depend on information combined from two observations—the order of their onsets and the order of their offsets.) If onsets or offsets are used as stimuli, however, the durations must be either long or randomized, to avoid duration cues that are correlated with temporal order.

#### D. CONTROL OF ATTENTIONAL BIAS

In Section VI we mentioned some of the dangers associated with uncontrolled attentional bias. One way to deal with the possibility of prior-entry effects that might vary from one condition to another is to force a particular

bias. But methods that might do this have yet to be adequately tested in the context of TOJs. A second way is to randomize conditions (such as stimulus intensities) from trial to trial, so that even if the bias fluctuates it is not confounded with condition. Where condition differences are determined by stimulus features that are apparent before the events to be judged, as in Hansteen's experiment (Section VIII,C), the randomization method cannot be used. Even in the absence of this difficulty, the usefulness of the randomization method is limited if attentional bias interacts with experimental factors that influence the channels. Fluctuations in bias will, of course, add unknown variance to the psychometric function. And the randomization method may not be usable with multiple-observation or forced-choice paradigms, since one presentation might systematically influence the bias adopted for the others.

#### E. DANGERS OF AVERAGING

We have already cautioned against analyses based on probability of "correct" judgments in the method of single stimuli. In some studies, an average of two functions is reported:  $F(d)$  for  $d \geq 0$  (the part of the psychometric function to the right of zero), and  $1 - F(-d)$  for  $d \leq 0$  (the complement of the part of the function to the left of zero). These two measures of "correctness" estimate the same function only if  $\mathbf{D}$  is distributed symmetrically about zero (implying a zero PSS). Even if  $\mathbf{D}$  is symmetric, but about some value other than zero, such analyses are likely to obscure and mislead. For example, if  $F(d)$  is a normal ogive with nonzero mean, the mean probability correct obtained in this way is an S-shaped function of  $|d|$ , rather than being the concave-downward right half of the ogive.

If there are any differences in PSS among psychometric functions, averaging will tend both to reduce the estimated judgmental precision and to lead to distortions of shape. This is true for averaging over subjects in a single-stimulus paradigm for example, and for averaging over the two presentation orders in a two-alternative forced-choice paradigm.

#### F. ESTIMATION OF CUMULANTS OF THE PSYCHOMETRIC FUNCTION

An empirical psychometric function provides us directly with a small set of quantiles of the  $\mathbf{D}$  distribution. But the simple, distribution-free consequences of the theoretical developments presented in this paper are stated in terms of the mean, variance, and higher cumulants of the  $\mathbf{D}$  distribution. These quantities cannot be estimated from a small set of quantiles without making assumptions about the form of the psychometric function, or the

relation among the forms of a set of functions. In our view this is the most serious methodological problem associated with the ideas we have presented (see Section II,D). By fitting smooth functions from a specified family to empirical psychometric functions as, for example, in probit analysis (Finney, 1952), the problem can be completely solved, but we have little basis at present for choosing the family. The use of Spearman's (1908) method and its generalization (Epstein & Churchman, 1944; see also Finney, 1964) requires assumptions about the form of the psychometric function that are substantially weaker, and thus more acceptable. This method treats the empirical psychometric function as a cumulative grouped frequency distribution of **D** values, and leads relatively directly to estimates of its mean and higher cumulants, for which Sheppard's corrections for grouping may be appropriate (see Kendall & Stuart, 1958).

Some particular estimates using only one or two quantiles can be made on the basis of assumptions that are relatively weak and at least partially testable. For example, the assumption that the **D** distribution is symmetric about its mean permits the mean to be estimated; the assumption that a set of psychometric functions differ only in origin permits differences in mean to be estimated; the assumption that a set of functions differ only in origin and scale (have the same "shape") permits tests of additivity of variances.

## **XI. Real-Time Processing without Memory**

As we have said earlier, all the models of temporal-order perception that we know of are special cases of the general independent-channels model, and the validity of using order judgments to measure perceptual latency depends on the validity of the model. Since the model is plausible and attractive, it seems worthwhile to emphasize some of its special features and hint at alternatives one might consider.

In the general model and its special cases, the decision mechanism is thought of as collecting all its information from the sensory channels in real time, with minimal reliance on memory. This property is particularly evident for decision mechanisms that depend on periodic sampling or attention switching.

Within each channel, none of the particular models makes use of more than one point of access to the flow of information. For example, an early stage does not feed information forward to a later stage, before the signal itself arrives, to provide a warning that attention must be switched. Instead, the level at which signals are selected by attention is the same as the level at which their arrivals control the switching of attention. Moreover, even if the detailed structure of an internal response is stored for other purposes, each

channel furnishes only a single time value to the decision mechanism—a value that could be derived from the internal response by, for example, a memoryless threshold device.<sup>41</sup>

It is the real-time character of the processing of signals that suggests treating internal time as homogeneous at the level of the arrivals, so that the mean difference between arrival times differs at most by an additive constant from the physical difference between stimulus times. This psychophysical relation contrasts with most others, from which nonlinear internal transformations are inferred (Stevens, 1970).

For purposes of TOJs, then, we have been assuming that the internal responses to stimuli are not laid out in some display area where their structures and temporal relations can be scrutinized at leisure by the homunculus. In other words, we have assumed that the homunculus, like man, experiences the world in three dimensions rather than four. Following Efron's (1963c) lead of drawing inspiration from the antiheroes of contemporary fiction, perhaps we should consider Vonnegut's Tralfamadorians in devising an alternative model of the homunculus:

The Tralfamadorians can look at all the different moments just the way we can look at a stretch of the Rocky Mountains, for instance. They can see how permanent all the moments are, and they can look at any moment that interests them. It is just an illusion we have here on Earth that one moment follows another one, like beads on a string, and that once a moment is gone it is gone forever.<sup>42</sup>

Clearly the homunculus *is* Tralfamadorian to some extent, since man can store at least crude information about the temporal structure of experience. However, if further research supports the independent-channels model, with its real-time characteristics, we would conclude that memory for temporal arrangements plays no role in TOJs of nearly-simultaneous stimuli. This could reflect a limitation on memory: stored temporal information might be incapable of yielding the fine temporal resolution of a real-time process.

---

<sup>41</sup>If the decision mechanism does use single time values rather than more detailed internal responses (which might differ in structure from one stimulus to another or one channel to another), this would be consistent with supposing that (a) equal-magnitude arrival-time differences of opposite sign are equally discriminable from simultaneous arrivals (symmetric decision function), and that (b) the decision function is the same, regardless of the particular events whose order is judged.

<sup>42</sup>From Kurt Vonnegut, Jr. *Slaughterhouse 5 or the children's crusade*, p. 23. New York: Delacorte Press, 1969. By permission of Delacorte Press and Seymour Lawrence, Inc.

### Glossary

Here we provide a list of the main symbols used in order of appearance in the text, with brief definitions and numbers of the sections in which they are introduced. Note that symbols in boldface represent random variables; the same symbols in italics represent values of these random variables.

TOJ	Abbreviation of the term "temporal-order judgment." I.
$S_x$	Stimulus in channel $x$ . I,A.
$t_x$	Time at which $S_x$ is presented. I,A.
$d(x, y)$	$t_y - t_x$ . I,A.
" $t_x < t_y$ "	Subjective report that $S_x$ appears to occur before $S_y$ . I,A.
$F(d)$	Psychometric function: $\Pr\{t_x < t_y\}$ as a function of $d(x, y)$ . I,A.
$D(x, y)$	Random variable defined such that $\Pr\{D(x, y) \leq d\} = F(d)$ is its distribution function. I,A.
$PSS(x, y)$	Point of subjective simultaneity: a value of $d$ . I,A.
$d_{1/2}$	Median of $D$ distribution: one definition of PSS. I,A.
$d_\mu$	Mean of $D$ distribution: another definition of PSS. I,A.
$E( )$	Expectation. I,A.
$DL$	Difference threshold: half the change in $d$ required to increase $F(d)$ from .25 to .75. I,A.
$R_x$	Arrival latency for $S_x$ at locus of order-decision mechanism. I,A.
$U_x$	Arrival time for $S_x$ : $R_x + t_x$ . II,A.
$G$	Decision function giving $\Pr\{t_x < t_y\}$ as a function of $U_y - U_x$ . II,A.
$\Delta(x, y)$	Random variable defined such that $\Pr\{\Delta(x, y) \leq v\} = G(v)$ . II,D.
RT	Abbreviation of the term "reaction time." III.
<b>T</b>	Reaction time. III.
<b>M</b>	Duration, including motor time, of processing stages that "follow" order mechanism. III.
$\text{Var}( )$	Variance. III,A.
$E_x$	Attribute of stimulus $S_x$ , such as its intensity. III,B.
$\kappa_r$	Cumulant of $r$ th order. III,B.
$I(x, y, z)$	$D(x, y) + D(y, z) + D(z, x)$ . VIII,A.
$\bar{I}$	$E(I)$ : an index of intransitivity. VIII,A.
$\bar{I}_R$	Component of intransitivity associated with arrival latencies. VIII,A.
$\bar{I}_\Delta$	Component of intransitivity associated with decision mechanism. VIII,A.

### Acknowledgments

Discussions with several colleagues contributed to this paper; we particularly thank D. F. Andrews, F. K. Hwang, and C. L. Mallows for their advice. We also thank R. Efron, J. C. Falmagne, A. B. Kristofferson, T. K. Landauer, J. D. Mollon, R. Rutschmann, and especially L. B. Boza, C. S. Harris, and D. E. Meyer, for helpful comments on earlier drafts, and S. M. Anstis, T. R. Corwin, R. W. Hansteen, H. H. Matteson, A. M. Prestrude, and B. J. Rogers for furnishing us with unpublished details of their data.

## References

- Alpern, M. A note on visual latency. *Psychological Review*, 1968, **75**, 260–264.
- Babkoff, H., & Sutton, S. Perception of temporal order and loudness judgments for dichotic clicks. *Journal of the Acoustical Society of America*, 1963, **35**, 574–577.
- Babkoff, H., & Sutton, S. Monaural temporal interactions. *Journal of the Acoustical Society of America*, 1971, **50**, 459–465.
- Baron, J. Temporal ROC curves and the psychological moment. *Psychonomic Science*, 1969, **15**, 299–300.
- Baron, J. The threshold for successiveness. Unpublished doctoral dissertation, University of Michigan, 1970.
- Baron, J. The threshold for successiveness. *Perception & Psychophysics*, 1971, **10**, 201–207.
- von Békésy, G. Interaction of paired sensory stimuli and conduction in peripheral nerves. *Journal of Applied Physiology*, 1963, **18**, 1276–1284.
- von Békésy, G. The smallest time difference the eyes can detect with sweeping stimulation. *Proceedings of the National Academy of Sciences*, 1969, **64**, 142–147.
- Bernhard, C. G. Contributions to the neurophysiology of the optic pathway. *Acta physiologica Scandinavica*, **1**, Suppl. 1, 1940.
- Bernstein, I. H., Rose, R., & Ashe, V. M. Energy integration in intersensory facilitation. *Journal of Experimental Psychology*, 1970, **86**, 196–203.
- Bertelson, P., & Tisseyre, F. Apparent order and stimulus uncertainty. *Psychonomic Science*, 1969, **15**, 65–66.
- Biederman-Thorson, M., Thorson, J., & Lange, G. D. Apparent movement due to closely spaced sequentially flashed dots in the human peripheral field of vision. *Vision Research*, 1971, **11**, 889–903.
- Boring, E. G. *A history of experimental psychology*. 2nd ed. New York: Appleton, 1950.
- Bregman, A. S., & Campbell, J. Primary auditory stream segregation and perception of order in rapid sequences of tones. *Journal of Experimental Psychology*, 1971, **89**, 244–249.
- Chapman, R. M. Spectral sensitivities of neural impulses and slow waves in the bullfrog retina. *Vision Research*, 1962, **2**, 89–102.
- Corwin, T. R., & Boynton, R. M. Transitivity of visual judgments of simultaneity. *Journal of Experimental Psychology*, 1968, **78**, 560–568.
- David, E. E., Jr., Guttman, N., & van Bergeijk, W. A. On the mechanism of binaural fusion. *Journal of the Acoustical Society of America*, 1958, **30**, 801–802.
- David, E. E., Jr., Guttman, N., & van Bergeijk, W. A. Binaural interaction of high-frequency complex stimuli. *Journal of the Acoustical Society of America*, 1959, **31**, 774–782.
- Deatherage, B. H., & Hirsh, I. J. Auditory localization of clicks. *Journal of the Acoustical Society of America*, 1959, **31**, 486–492.
- Dunlap, K. The complication experiment and related phenomena. *Psychological Review*, 1910, **17**, 157–191.
- Efron, R. The effect of handedness on the perception of simultaneity and temporal order. *Brain*, 1963, **86**, 261–284. (a)
- Efron, R. The effect of stimulus intensity on the perception of simultaneity in right- and left-handed subjects. *Brain*, 1963, **86**, 285–294. (b)
- Efron, R. Temporal perception, aphasia and déjà vu. *Brain*, 1963, **86**, 403–424. (c)
- Eijkman, E., & Vendrik, A. J. H. Can a sensory system be specified by its internal noise? *Journal of the Acoustical Society of America*, 1965, **37**, 1102–1109.
- Epstein, B., & Churchman, C. W. On the statistics of sensitivity data. *Annals of Mathematical Statistics*, 1944, **15**, 90–96.

- Erlebacher, A., & Sekuler, R. Response frequency equalization: A bias model for psychophysics. *Perception & Psychophysics*, 1971, **9**, 315–320.
- Finney, D. J. *Probit analysis: A statistical treatment of the sigmoid response curve*. (2nd ed.) London: Cambridge Univ. Press, 1952.
- Finney, D. J. *Statistical method in biological assay*. (2nd ed.) London: Griffin, 1964.
- Gengel, R. W., & Hirsh, I. J. Temporal order: The effect of single versus repeated presentation, practice, and verbal feedback. *Perception & Psychophysics*, 1970, **7**, 209–211.
- Gibbon, J., & Rutschmann, R. Temporal order judgment and reaction time. *Science*, 1969, **165**, 413–415.
- Green, D. M. Temporal auditory acuity. *Psychological Review*, 1971, **78**, 540–551.
- Green, D. M., & Henning, G. B. Audition. *Annual Review of Psychology*, 1969, **20**, 105–128.
- Green, D. M., & Swets, J. A. *Signal detection theory and psychophysics*. New York: Wiley, 1966.
- Grice, G. R. Stimulus intensity and response evocation. *Psychological Review*, 1968, **75**, 359–373.
- Guilford, J. P. *Psychometric methods*. 2nd ed. New York: McGraw-Hill, 1954.
- Haftner, E. R., & Jeffress, L. A. Two-image lateralization of tones and clicks. *Journal of the Acoustical Society of America*, 1968, **44**, 563–569.
- Halliday, A. M., & Mingay, R. On the resolution of small time intervals and the effect of conduction delays on the judgment of simultaneity. *Quarterly Journal of Experimental Psychology*, 1964, **16**, 35–46.
- Hansteen, R. W. Visual latency as a function of stimulus onset, offset and background luminance. Unpublished doctoral dissertation, Tulane University, 1968.
- Hansteen, R. W. Visual latency as a function of stimulus onset, offset, and background luminance. *Journal of the Optical Society of America*, 1971, **61**, 1190–1195.
- Hill, J. W., & Bliss, J. C. Perception of sequentially presented tactile point stimuli. *Perception & Psychophysics*, 1968, **4**, 289–295.
- Hirsh, I. J. Auditory perception of temporal order. *Journal of the Acoustical Society of America*, 1959, **31**, 759–767.
- Hirsh, I. J., & Fraisse, P. Simultanéité et succession de stimuli hétérogènes. *L'Année Psychologique*, 1964, **64**, 1–19.
- Hirsh, I. J., & Sherrick, C. E., Jr. Perceived order in different sense modalities. *Journal of Experimental Psychology*, 1961, **62**, 423–432.
- Ibragimov, I. A. On the composition of unimodal distributions. *Theory of probability and its applications*, 1956, **1**, 255–260.
- John, I. D. A statistical decision theory of simple reaction time. *Australian Journal of Psychology*, 1967, **19**, 27–34.
- John, I. D. Some variables affecting judgments of auditory temporal numerosity. Unpublished manuscript, 1971.
- Julesz, B. *Foundations of cyclopean perception*. Chicago: Univ. of Chicago Press, 1971.
- Julesz, B., & White, B. Short-term visual memory and the Pulfrich phenomenon. *Nature*, 1969, **222**, 639–641.
- Kappauf, W. E. An empirical sampling study of the Dixon and Mood statistics for the up-and-down method of sensitivity testing. *American Journal of Psychology*, 1969, **82**, 40–55. (a)
- Kappauf, W. E. Use of an on-line computer for psychophysical testing with the up-and-down method. *American Psychologist*, 1969, **24**, 207–211. (b)
- Kappauf, W. E., & Yeatman, F. R. Visual on- and off-latencies and handedness. *Perception & Psychophysics*, 1970, **8**, 46–50.
- Kendall, M. G., & Stuart, A. *The advanced theory of statistics*. Vol. I. London: Griffin, 1958.
- Kristofferson, A. B. Discrimination of successiveness: A test of a model of attention. *Science*, 1963, **139**, 112–113.

- Kristofferson, A. B. Attention and psychophysical time. In A. F. Sanders (Ed.), *Attention and Performance. Acta Psychologica*, 1967, **27**, 93–100. (a)
- Kristofferson, A. B. Successiveness discrimination as a two-state, quantal process. *Science*, 1967, **158**, 1337–1339. (b)
- Kristofferson, A. B. "Attention" in R. M. Patton, T. A. Tanner, Jr., J. Markowitz, & J. A. Swets (Eds.), *Applications of research on human decisionmaking*. Washington, D.C.: NASA, 1970. Pp. 49–64.
- Ladefoged, P., & Broadbent, D. E. Perception of sequence in auditory events. *Quarterly Journal of Experimental Psychology*, 1960, **12**, 162–170.
- Levick, W. R. Variation in the response latency of cat retinal ganglion cells. Unpublished manuscript, 1972.
- Levick, W. R., & Zacks, J. L. Responses of cat retinal ganglion cells to brief flashes of light. *Journal of Physiology*, 1970, **206**, 677–700.
- Levinson, J. Z. Flicker fusion phenomena. *Science*, 1968, **160**, 21–28.
- Levitt, H. Transformed up-down methods in psychoacoustics. *Journal of the Acoustical Society of America*, 1971, **49**, 467–477.
- Liberman, A. M., Harris, K. S., Kinney, J. A., & Lane, H. The discrimination of relative onset-time of the components of certain speech and nonspeech patterns. *Journal of Experimental Psychology*, 1961, **61**, 379–388.
- Lit, A. The magnitude of the Pulfrich stereophenomenon as a function of binocular differences of intensity at various levels of illumination. *American Journal of Psychology*, 1949, **62**, 159–181.
- Matteson, H. H. Effects of surround luminance on perceptual latency. *Journal of the Optical Society of America*, 1970, **60**, 1125–1131.
- Matteson, H. H., Lewis, J. H., & Dunlap, W. P. Effects of stimulus duration on temporal facilitation. Paper presented at the meeting of the Psychonomic Society, St. Louis, Missouri, November 1971.
- Miller, J. M., & Glickstein, M. Neural circuits involved in visuomotor reaction time in monkeys. *Journal of Neurophysiology*, 1967, **30**, 399–414.
- Miller, J. M., Moody, D. B., & Stebbins, W. C. Evoked potentials and auditory reaction time in monkeys. *Science*, 1969, **163**, 592–594.
- Mollon, J. D. Temporal factors in perception. Unpublished doctoral thesis, University of Oxford, 1969.
- Mollon, J. D., & Krauskopf, J. Reaction time as a measure of the temporal response properties in individual colour mechanisms. *Vision Research*, 1972, in press.
- Moray, N. *Attention: Selective processes in vision and hearing*. London: Hutchinson, 1969.
- Murray, H. G. Stimulus intensity and reaction-time: Evaluation of a decision-theory model. *Journal of Experimental Psychology*, 1970, **84**, 383–391.
- Needham, J. G. Some conditions of prior entry. *Journal of General Psychology*, 1936, **14**, 226–240.
- Oatley, K., Robertson, A., & Scanlan, P. M. Judging the order of visual stimuli. *Quarterly Journal of Experimental Psychology*, 1969, **21**, 172–179.
- Pinheiro, M. L., & Ptacek, P. H. Reversals in the perception of noise and tone patterns. *Journal of the Acoustical Society of America*, 1971, **49**, 1778–1782.
- Prestrude, A. M. Visual latencies at photopic levels of retinal illuminance. *Vision Research*, 1971, **11**, 351–361.
- Raab, D. H. Statistical facilitation of simple reaction times. *Transactions of the New York Academy of Sciences*, 1962, **24**, 574–590.
- Reber, A. S., & Anderson, J. R. The perception of clicks in linguistic and nonlinguistic messages. *Perception & Psychophysics*, 1970, **8**, 81–89.
- Rogers, B. J., & Anstis, S. M. Intensity versus adaptation and the Pulfrich stereophenomenon.



- Vision Research*, 1972, **12**, 909–928.
- Roufs, J. A. J. Perception lag as a function of stimulus luminance. *Vision Research*, 1963, **3**, 81–91.
- Rubin, E. Geräuschverschiebungsversuche. *Acta Psychologica*, 1938, **4**, 203–236.
- Rutschmann, J., & Link, R. Perception of temporal order of stimuli differing in sense mode and simple reaction time. *Perceptual and Motor Skills*, 1964, **18**, 345–352.
- Rutschmann, R. Perception of temporal order of electrocutaneous stimuli and simple reaction time. Paper presented at the meeting of the Eastern Psychological Association, Boston, Massachusetts, April 1967.
- Rutschmann, R. Perception of temporal order of auditory stimuli and simple reaction time. Paper presented at the meeting of the Eastern Psychological Association, Philadelphia, Pennsylvania, April 1969.
- Sanford, A. J. Effects of changes in the intensity of white noise on simultaneity judgements and simple reaction time. *Quarterly Journal of Experimental Psychology*, 1971, **23**, 296–303.
- Sanford, E. C. The personal equation. *American Journal of Psychology*, 1888, **2**, 3–38, 271–298, 403–430.
- Smith, M. C. Theories of the psychological refractory period. *Psychological Bulletin*, 1967, **67**, 202–213.
- Spearman, C. The method of 'right and wrong cases' ('constant stimuli') without Gauss's formulae. *British Journal of Psychology*, 1908, **2**, 227–242.
- Sperling, G. Successive approximations to a model for short term memory. In A. F. Sanders (Ed.), *Attention and Performance*. *Acta Psychologica*, 1967, **27**, 285–292.
- Sperling, G., & Sondhi, M. M. Model for visual luminance discrimination and flicker detection. *Journal of the Optical Society of America*, 1968, **58**, 1133–1145.
- Sternberg, S. The discovery of processing stages: Extensions of Donders' method. In W. G. Koster (Ed.), *Attention and Performance II*. *Acta Psychologica*, 1969, **30**, 276–315. (a)
- Sternberg, S. Memory-scanning: Mental processes revealed by reaction-time experiments. *American Scientist*, 1969, **57**, 421–457. (b)
- Sternberg, S., Knoll, R. L., & Gates, B. A. Prior entry reexamined: Effect of attentional bias on order perception. Paper presented at the meeting of the Psychonomic Society, St. Louis, Missouri, November 1971.
- Stevens, S. S. Neural events and the psychophysical law. *Science*, 1970, **170**, 1043–1050.
- Stone, S. A. Prior entry in the auditory-tactual complication. *American Journal of Psychology*, 1926, **37**, 284–287.
- Stroud, J. M. The fine structure of psychological time. In H. Quastler (Ed.), *Information theory in psychology*. Glencoe, Illinois: Free Press, 1955. Pp. 174–205.
- Thomas, G. B., Hill, P. B., Carroll, F. S., & Garcia, B. Temporal order in the perception of vowels. *Journal of the Acoustical Society of America*, 1970, **48**, 1010–1013.
- Thompson, R. F., Smith, H. E., & Bliss, D. Auditory, somatic sensory, and visual response interactions and interrelations in association and primary cortical fields of the cat. *Journal of Neurophysiology*, 1963, **26**, 365–378.
- Titchener, E. B. *Lectures on the elementary psychology of feeling and attention*. New York: MacMillan, 1908.
- Vaughan, H. G., Jr., Costa, L. D., & Gilden, L. The functional relation of visual evoked response and reaction time to stimulus intensity. *Vision Research*, 1966, **6**, 645–656.
- Venables, P. H. Periodicity in reaction time. *British Journal of Psychology*, 1960, **51**, 37–43.
- Vonnegut, K., Jr. *Slaughterhouse five*. New York: Delacorte, 1969.
- Warren, R. M., Obusek, C. J., Farmer, R. M., & Warren, R. P. Auditory sequence: Confusion of patterns other than speech or music. *Science*, 1969, **164**, 586–587.
- White, C. T. Temporal numerosity and the psychological unit of duration. *Psychological Monographs*, 1963, **77**, No. 12.

- White, C. T., & Lichtenstein, M. Some aspects of temporal discrimination. *Perceptual and Motor Skills*, 1963, **17**, 471-482.
- Wilson, J. A., & Anstis, S. M. Visual delay as a function of luminance. *American Journal of Psychology*, 1969, **82**, 350-358.
- Zacks, J. L. Estimation of the variability of the latency of responses to brief flashes. *Vision Research*, 1972, in press.